

LIVING MARXISM LM104 UK £2.50 OCTOBER 1997 US\$6 DM9 FF27 IR£2.50

# LM104

The mag ITN wants to gag

New religion,  
new ruling elite:  
Blair's Britain AD  
(After Diana)

## MOURNING SICKNESS

THE DUMBING DOWN  
OF HIGHER EDUCATION

WHO NEEDS A  
PRIVACY LAW?

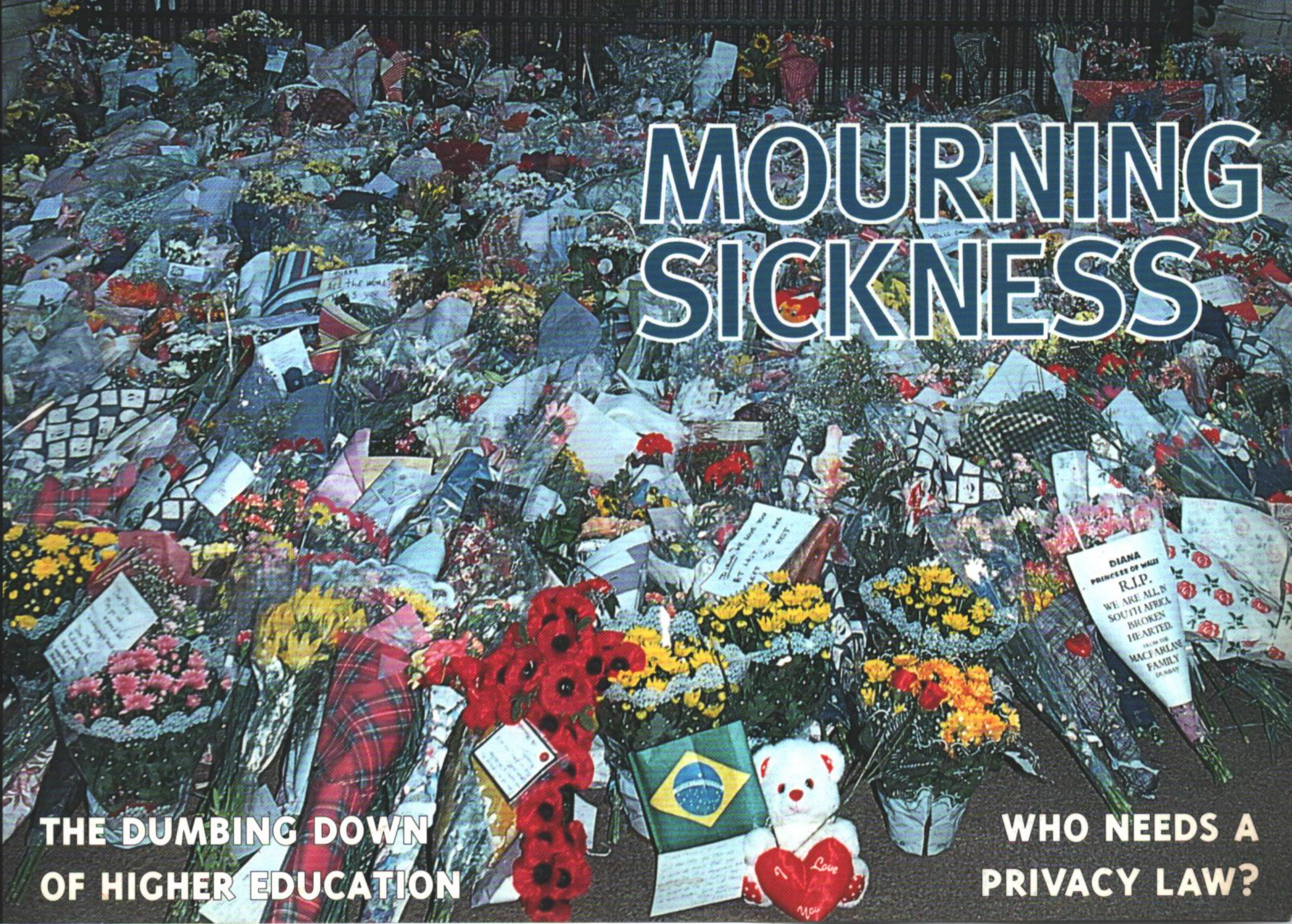



**LM**

the  
**TRUTH**  
is in  
here

## Subscribe

A year's subscription to *LM* will cost you just £23.50. Write to *LM* Subscriptions (104), BM JP Graphics, London WC1N 3XX; phone (0171) 278 7699; fax (0171) 278 9755; e-mail [lm@jpgraphics.co.uk](mailto:lm@jpgraphics.co.uk)

## Back issues

£3 including p&p. Make cheques payable to JP Graphics and send to BM JP Graphics, London WC1N 3XX

**99**

The counselling industry; ITN v *LM*: threats, writs and videotape; The right to be offensive; Should failed students sue?; Send in the clones: In defence of Dolly; Larry Flynt

**100**

Whatever happened to freedom?; Nightmare on Downing Street; The picture that fooled the world; New revelations; Libel laws: Censorship for hire; *Crash* producer hits back

**101**

Thou Shalt Not: the Tony Blair Commandments; Hutu refugees: blood on whose hands?; *LM* v ITN: there are camps, and there are concentration camps; Who made freedom a dirty word?; Monkey art

**102**

Media monsters: Radovan Karadzic and Neil Hamilton interviews; ITN on trial; Child Labour, New Danger?; Popping mad about alcopops; Do genes influence intelligence?; Hong Kong goes home; Bullfighting

**103**

Rwanda: Inside the Genocide Tribunal; The politics of corruption; Lunch break abortions; Rape and rape law; Bosnia: More democratisers, less democracy; Water shortages?; Nicholas Saunders on E

4	<b>MOURNING SICKNESS</b> <i>LM writers give an alternative view of the national grief-fest and what it says about Blair's Britain AD (After Diana)</i>
10	LM-mail
12	TABOOS: The case for kids <i>Ann Bradley</i>
15	<b>THE RIGHTS AND WRONGS OF PRIVACY</b> <i>Helen Searls</i>
18	Why are journalists so defensive? <i>Tessa Mayes</i>
20	<b>LM v ITN</b>
22	Northern exposure <i>Jennie Bristow</i>
24	<b>THE DUMBING DOWN OF HIGHER EDUCATION</b> <i>Claire Fox</i>
28	Second class students <i>Brendan O'Neill</i>
31	War crimes: Remember My Lai? <i>Dave Hallsworth</i>
32	<b>VIDEOS AND VIOLENCE: 'A SCIENTIFIC CASE FOR CENSORSHIP?'</b> <i>Andrew Calcutt</i>
34	FUTURES: Transport policy on the road to nowhere <i>Austin Williams</i>
37	Alcopops: the hidden agenda <i>Jennie Bristow</i>
38	<b>ALT.CULTURE.LM</b> <i>Football: using our religion; Boxing KO'd; Sean Hughes; Cartooning for equality</i>
42	APPEAL: In defence of free speech
43	<b>READING BETWEEN THE LINES</b> <i>Are poverty and ill-health really getting worse?</i>

# BACK TO COLLEGE



## THE DUMBING DOWN OF HIGHER EDUCATION centre pages

If New Labour is allowed to get away with implementing the *Dearing Report*, says Claire Fox, it is likely to mean the end of university life as we know it

## SECOND CLASS STUDENTS page 28

Who benefits from the new policy of lowering university standards in order to get more working class and disadvantaged students into higher education, asks Brendan O'Neill

## NORTHERN EXPOSURE page 22

A college photography tutor has been forced to resign for treating mature students like adults. Jennie Bristow reports from Teeside

# LM104

EDITOR: **Mick Hume**  
 ALT.CULTURE: **Andrew Calcutt**  
 BOOKS: **James Heartfield**  
 DESIGN: **Alex Cameron, JP Graphics**  
 PRODUCTION: **Dave Chapman, Mark Bowman**

PUBLISHED BY: **InformInc, BM InformInc, London, WC1N 3XX**  
 EDITORIAL: **(0171) 278 9908**  
 EMAIL: **lm@informinc.co.uk**  
 WWW: **www.informinc.co.uk**

● JP Graphics Ltd, BM JP Graphics, London WC1N 3XX, subscriptions (0171) 278 7699  
 ● US mailing address: LM, PO Box 769, Murray Hill Station, New York, NY 10156 ● Distributed in the UK by Comag Magazine Marketing, Tavistock Road, West Drayton, Middlesex, UB7 7QE; Phone: West Drayton (01895) 444 055; Fax (01895) 455 255; Telex 881 3787 ● Distributed in the USA by Ingram Periodicals Inc, 1226 Heil Quaker Boulevard, Post Office Box 7000, La Vergne, TN 37086-7000; Phone (615) 793 5522 and Bernhard DeBoer Inc, 113 East Centre Street, Nutley, New Jersey 07110; Phone (201) 667 9300 ● © copyright LM ● Printed by Carodruck, Frankfurt, Germany ● ISSN 0955-2448 October 1997. Unsolicited manuscripts are welcome, but can only be returned if an SAE is enclosed

# BLAIR'S BRITAIN AD— AFTER DIANA

**Mick Hume**

*'The triumph of the New Labour establishment over the old was evident at the funeral, where the charity workers replaced the generals and Elton John took the part of Vera Lynn'*

**So what** was all that really about? How could the death of a celebrity princess in a drink-driving accident spark off such an unprecedented national grief-fest? And what does the reaction tell us about the state of British society AD—After Diana?

The emotional outburst was about something more than the death of Diana. Many who mourned admitted as much, when they said they had been shocked by the intensity of their own feelings on hearing the news. Overnight, normally rational people somehow felt they 'knew' and even 'loved' a woman who in life had meant no more to them than any other soap opera star.

Britain was clearly ready for a tragedy, in the mood for mourning, geared up to grieve over something. Diana's death provided a pretext for these pent-up emotions to come out. That was why it could so quickly assume a symbolic significance out of all proportion to the event.

The real significance of the funeral and related tributes was that they allowed millions to come together in a kind of community of suffering. At a time when many have lost faith in the old traditions and values which once held them together, when society seems ever-more fragmented, this was a rare opportunity for the nation to speak with a common voice.

**People searching** anxiously for some certainty and sense of belonging in their lives grabbed that opportunity with both hands, joining in any new ritual—the laying of flowers, the queuing for hours to sign books of commemoration—that could give a fleeting sense of being 'all in this together', of sharing pain and a sense of loss.

Diana herself may not have been the reason why these rituals took hold so strongly; but as the woman who went on television to advertise her own experience of pain and victimhood as her credentials to be 'Queen in people's hearts', she was the perfect focus around which the community of suffering could unite. Diana was an idol whose time had come.

But the reaction to Diana's death did more than capture the mood of the moment. It also confirmed some important changes that will still be making themselves felt long after the floral tributes have wilted. Perhaps most importantly, it revealed a major shift at the top of society, with the triumph of the New Labour elite and its values over the old British establishment.



PHOTO: MICHAEL WALTER

'I want to begin by saying how proud I was to be British on Saturday', Tony Blair told the TUC the week after the funeral, 'when the whole world could see our country united in grief, compassion and a determination that her memory should be honoured and good made to come of the tragedy that was her death'.

For Blair's team this was not just a tragedy to be mourned, but an opportunity to celebrate a new sense of national unity. In the absence of anything else, national grief became the symbol of the British way of life, and New Labour waved it for all it was worth. They have learned that, in our modern society of atomised and anxious individuals, they have far more power to shape and structure popular opinion

through the media. Much of what was seen as a spontaneous expression of the will of 'the People'—the backlash against royal protocol and the protests about press intrusion, for example—was in fact orchestrated from the top.

New Labour and its supporters successfully manipulated the mood of national mourning in order to secure their own authority. From the Queen downwards, the old establishment simply crumbled and gave in to every one of their demands: lower that flag, launch that charity, cry those tears, sing that song, applaud that speech, restrain those reporters.

The Blairs, soulmates of Princess Diana, spoke for the nation. New Tory leader William Hague might as well have been in Balmoral for all the say he had. The triumph of the New Labour establishment over the old was evident during the funeral at Westminster Abbey, where the charity workers replaced the generals and Elton John took the part of Vera Lynn.

**Many see** these changes as a positive part of New Labour's modernisation plans. After all, who would want to defend the values of the old establishment, whether it be the traditional monarchy or the Murdoch press? But if you think they were bad, look at what is replacing them.

What exactly is the new society that Blair wants us to be proud of? It is a society whose values are so degraded and expectations so low that it can only feel united and morally virtuous in response to tragedy and loss. As other writers in the pages that follow indicate, the dominant Diana-speak of the age embraces the infantile notion that emotions are superior to intellect as a guide to life. It focuses on the suffering of victims rather than the achievements of heroes; so Earl Spencer's funeral oration spoke of Diana's 'vulnerability' and 'insecurity' as the qualities others could admire. Its message is that people are not really up to much, that we all need therapy and that the most we can do to change the world for the better is

to lay a few flowers and give each other one of Diana's famous hugs.

The new order also insists we conform to an etiquette as strict and coercive as any protocol of the past. So the media was subjected to the most stringent censorship to ensure nothing 'offensive' reached the public in the weeks after Diana's death. No criticisms of the princess were allowed, Di jokes were banned, anything 'tasteless' was taken off the air and the newsagent's shelves. And because it was done in the name of Diana, icon of the new Britain, nobody was allowed to complain.

**This is** the shape of things to come in Blair's Britain AD. Those who think we could never again witness such a mawkish display of mourning sickness as was seen around Diana's funeral should think again.

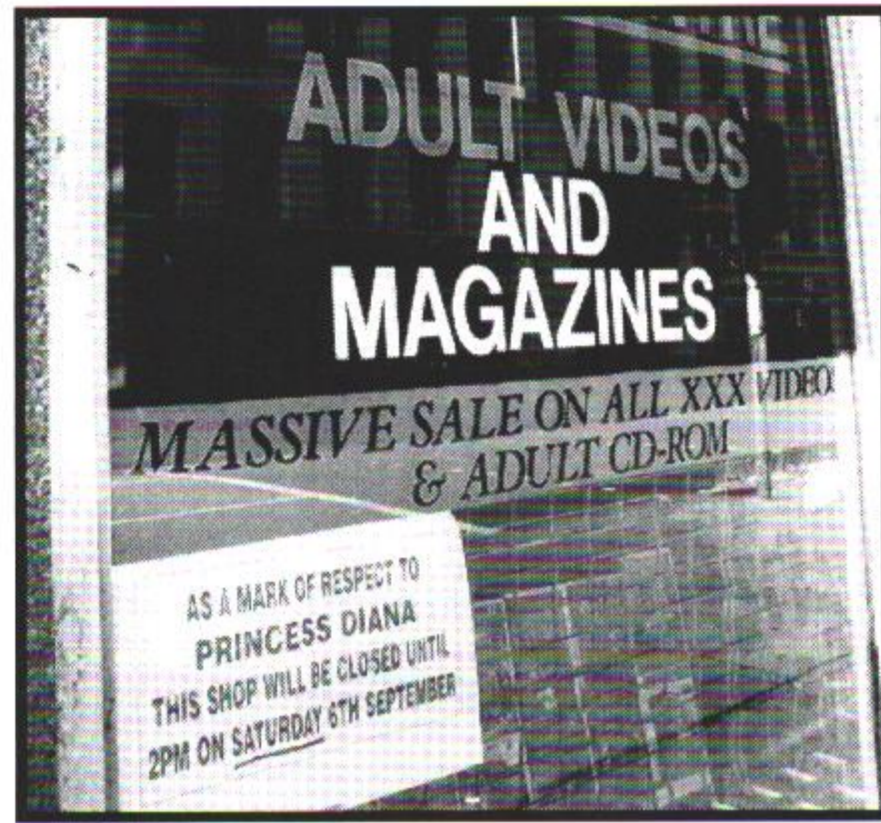

PHOTO: DAVE CHAPMAN

The reaction to Diana's death might have been described as 'unique', but in fact it fits into a pattern of disparate events over the past couple of years which have been turned

into national carnivals for a community of suffering: the Dunblane massacre in Britain, the scandal over a paedophile murder ring in Belgium, the shooting of an anti-drugs journalist in Ireland, the killing of a local politician by the Basque separatist group ETA in Spain. Each of them sparked off huge outpourings of popular emotion, morbid expressions of national unity in suffering, and witch-hunts. Diana's death simply took these trends to new heights. Where will mourning sickness strike next?

After the response to Dunblane, *LM* identified a British society 'ill at ease with itself', with 'an insatiable appetite for victims'. We concluded: 'Bring on the next moral spectacle.' (May 1996) Princess Diana may well be 'irreplaceable' to those who worship her; but rest assured there will be another tragic victim along shortly. ●

## BEWARE THE RAMPANT ID

**Dr Michael Fitzpatrick**

*'Where is the evidence that these public displays of grief and emotion are therapeutic?'*

**The public** mourning for Princess Diana has been widely celebrated as confirming the ascendancy of the spirit of 'let it all hang out' California over 'buttoned-up' Britain. From Tony Blair's emotional statement of grief for the 'people's princess' to Charles Spencer's electrifying funeral oration, the virtues of open displays of feeling triumphed over the traditions of the stiff upper lip.

The contrast between 'reaching out' and 'holding in' is symbolised in the rift between Diana and the royal family. In the words of one typically sycophantic New Labour commentator, Diana's 'language was that of the personal, from emotion to pain, from the hug to the smile. In baring her soul, in admitting her weaknesses, in exposing her suffering, she spoke to and touched millions of people' (*New Statesman*, 5 September). In stark contrast, the House of Windsor rejected Diana, forced her sons to church within hours of her death, and remained silent at Balmoral until forced by popular demand to return to London, display grief in public and relax protocol for the funeral.

The new consensus is that the shift in the border between the public and the private is a step forward for the nation and is therapeutic for individuals coping with bereavement or loss. I wonder.

Underlying the outpouring of psychobabble around Diana's death is the presumption

that traditional mechanisms for coping with bereavement are outmoded. One of the privileges of working as a doctor is that you encounter many people undergoing traumatic experiences and discover a wide variety of ways of coming to terms with loss. Most people find comfort in some combination of private grieving and public ritual, according to tradition and preference. One common feature of different forms of mourning is the general indulgence towards



PHOTO: MICHAEL WALTER

the bereaved that allows them to grieve in their own way, whether they want to weep, talk or be alone.

The distinctive feature of the new, politically correct, form of mourning is its rigidly prescriptive and intolerant character. Following Diana's death the royal family was subjected to a grossly intrusive and authoritarian agenda: thou shalt break down and cry in public, hug estranged family members, submit to bereavement counselling. I have little sympathy for the House of Windsor, but I deeply object to the way that every family is increasingly subjected to similar pressures. If the new code can be imposed on the Queen, it can be imposed on anybody.

**Where is** the evidence that public displays of grief are therapeutic? I have often been impressed at people's remarkable capacity for coping with bereavements and other tragedies, through mourning and weeping, certainly, and also through getting on with life. By contrast, the culture of victimhood, of which Diana is now confirmed as the patron saint, seeks to confirm people's status as irrevocably damaged by their loss and requiring professional help in perpetuity.

The abandonment of cultural inhibitions on expressions of feeling—which is now universally approved, if not yet mandatory—may unleash negative as well as positive ►

◀ emotions. It is a familiar experience, reinforced by the response to the death of Diana, that bereavement provokes sentiments of anger as well as love, of cruelty and harshness as well as care and concern. Several commentators noted the 'ugly side' to the sanctification of Diana: the quest for scapegoats in the media, the demonisation of Prince Charles, the vilification of the royal family. This wave of vindictiveness reached its peak in Charles Spencer's bitter and vengeful panegyric.

In his 'dissection of personality' Sigmund Freud identified the id, the source of our most basic instinctual urges, as a dark, inaccessible and chaotic province of the mind. In the id there is no logic, no values, no morality, only a relentless striving for the satisfaction of instinctual needs. In Freud's theory, the emergence of the mature individual depends on the containment of the id, whose features are most strikingly manifested in the behaviour of the infant, within the developing human personality. This requires the cultivation of mechanisms of self-control through the assimilation of the values of society.

'Civilisation', wrote Freud, 'is built up upon a renunciation of instinct' (*Civilisation, Society and Religion*, Vol 12, Penguin Freud Library, p286). 'The sublimation of instinct is what makes it possible for higher psychical activities, scientific, artistic or ideological, to play such an important part in civilised life.' Taking up these themes in a perceptive commentary on the mourning for Diana, Anne Applebaum noted that 'the separation of the public and private spheres is what makes civilisation itself possible: if the demands of your emotional life are supreme, then they supersede the need for laws, the need for order, the need for work' (*Sunday Telegraph*, 7 September).

**The current** elevation of emotion over intellect is a decadent symptom of a society that, having lost confidence in itself, not only turns its back on the achievements of its own civilisation, but encourages a regression of the individual to a child-like state of surrender to instinctual urges. From this perspective, Charles Spencer's speech is best understood, not as a calculated onslaught on the monarchy, but as a tantrum. (You do not have to be a Windsor loyalist to agree with those who have observed that launching a dispute over the emotional custody of his nephews before an audience of millions revealed little concern for their welfare.)

The wave of applause for Spencer's speech that swept from the streets into Westminster Abbey reflects the morbid mood of our society. It revealed the tendency—among the public and the establishment alike—to surrender to the forces of irrationalism and infantilisation that have erupted with a particular intensity in response to the death of Diana. The rampant id is Di's most dangerous legacy. ●

# THE LONELY CROWD

Peter Ray

*'The real funeral, the sombre and dignified one, was taking place on television and we just provided the rushes from which it was edited together'*

**We were** in the centre of London but there was almost no traffic noise; we talked and smiled, even laughed, but we did it quietly, waiting politely to witness a historic spectacle. The monarchy's traditional East End following was there but they were easily matched by the West End rainbow coalition of twenty and thirtysomethings, students, professionals and tourists. There were rather more gay men than in a normal West End crowd, rather fewer blacks and Asians.

Noticeable by their absence were patriotic symbols. The symbols for this occasion were not Union flags but floral tributes. Also noticeably absent was black clothing. The crowd's casual dress was reported as testimony to Diana's celebrated informality. But it also suggested to me a profound uncertainty about exactly why we were there. After all, at the funerals of people we know and love we still generally wear black.

But perhaps the most surprising absences were tears. Few people cried, even after the cortege had passed. Perhaps they were all cried out at the end of a traumatic week but I doubt it. Most present were just not grieving or mourning in the conventional sense. The mood was something like a crowd at a festival or a fairground where all the acts or rides have been taken away. Apparently benign and relaxed but also blank and unfocused.

Nobody was raucous or consciously disrespectful, but sombre and dignified it was not. To be sombre or dignified you need precisely the element of formality which was missing. This was driven home to me outside St James' Palace just before the princes lined up for the procession. A woman had her radio on loudly, tuned to the commentary on the cortege passing through Hyde Park. The thought of being at a cricket match came to mind and I wondered why the radio was not upsetting people, but then I realised that the intoning of the BBC commentator added the sombre and dignified mood that we could not quite manage unaided.

After the short procession passed, a journalist loudly dictating copy into his mobile trotted out the 'sombre' and 'dignified' clichés we had all become familiar with, but did not really describe what we had

experienced just seconds before. He might as well have stayed in bed and dictated his copy from there. He had reminded us that the real funeral of Princess Diana, the sombre and dignified one, was taking place on television and we just provided the rushes from which it was edited together.

I joined the many people now taking in the huge floral tribute by the walls of St James'. It took a while to work out what these tributes symbolised so powerfully. As a public ritual they are just not British. The rows and rows of flowers, the photographs of the martyr repeated everywhere, the candles and the incense, all carried with them a whiff of the Ganges—a New Age image of the East. That is why it was so weird to see the head of the C of E inspecting them like she was on a visit overseas, and why she looked so weird while doing it. Perhaps these things mourned the failed national tradition that they replaced at this national occasion.

The sentimental personal messages reflected the falsehoods of the showbiz personality cults: the disturbing and bizarre sense of intimacy with the glamorous—who by definition are unavailable—and, in Diana's case, the camp inversion of values which revels in the romantic frustration and personal tragedy of a latter-day Judy Garland.

But the personal character of the tributes also told an important truth about our Americanised society. Almost nobody removed their flowers from the cellophane wrapping. To do so would be to lose the personal character of your tribute by dissipating it in the mass of flowers. On the surface these tributes represented a nation united in grief, yet they also seemed to symbolise the separateness of the crowds who laid them and looked at them; lonely crowds in which people's efforts to express their togetherness through ritualised grief only thinly disguised the real absence of communal feeling. The messages which showed many people convincing themselves that they knew Diana personally, are a frightening indication of how estranged they must feel from the people who really do live alongside them. This loneliness was more difficult to see at the real funeral of Diana, patron saint of the New Britain, the TV event I watched on video later. ●

# A TYRANNICAL NEW RELIGION

Mark Ryan

*'In its intolerance and self-serving piety, it is more than a match for any fanaticism the Catholic Church ever foisted on the world'*

The great public outpouring of grief and emotion surrounding the death of Diana had a deeply religious character about it, with its obligatory rituals, its unerring sense of where good and evil lie and in its saintly icons. It is the religion of feeling, the worship of the emotional. Those who fail to conform to the new orthodoxy, be they the royal family or the Scottish FA, risk invoking a furious rebuke. In its intolerance and self-serving piety, the new religion is more than a match for any fanaticism the Catholic Church ever foisted on the world.

Unlike traditional religion, the religion of feelings has no doctrine or dogmas. Ideas

woman who made the bleeding heart her own personal badge of honour, and to fume against those who declined to show the same levels of emotional incontinence. The strength of the new religion meant that even those who did not feel the same way felt unable to say so. The emotional spasm not only became an acceptable form of public expression, but actually became the only acceptable form of public expression. This was particularly remarkable in a country which has always prided itself on the virtues of restraint. All of a sudden, such virtues were signs of people 'in denial', concealing something sordid and most likely in need of

funeral procession. One of the interpreters explained the rationale for leaving the holy ones behind: 'We decided not to bring homeless people along. We wondered whether anybody vulnerable could take the pressure.'

The strength of the new religion was tested and showed its hand with the funeral oration of Earl Spencer. The fact that it was obvious from the previous Sunday morning that he was out of control, full of bitterness and vengeance should have sent any number of alarm bells ringing. There was a time when such a man would have been taken aside, plied with strong drink and told to shut up. Yet now it was precisely such a man who could best capture the spirit of the occasion. Spencer's emotional speech summed up many features of the new religion—Diana's unique ability to understand suffering because of the suffering she endured herself, something which gave her that sense of goodness and which put her at the opposite end of the moral spectrum from the editors of the tabloid newspapers. He lashed out at the media, the royals, the world that was not good enough for the beautiful Diana. It was a fire and brimstone sermon of pure feeling, to which the crowd outside responded with wild applause, and to which those gathered inside the cathedral spinelessly assented.

If the new emotionalism is a revolt against intelligence, it is also a caricature of true passion. While there were no inhibitions on the expression of grief, only grief was allowed. Anything which departed from the set script, or which smacked of any emotion other than grief was deemed unacceptable. This was most evident in the public demand that the Queen should grieve publicly on cue. That the Queen may have been subject to genuine emotions which meant that she did not feel like grieving, or at least not in the way outlined for her, seems not to have crossed anybody's mind.

Given the role of the late Diana in discrediting her dynasty, it is most unlikely that Her Majesty was bawling her eyes out into her pillow on hearing news of the accident in Paris. She was no doubt shocked and saddened by the news, but her feelings must also have been complex and contradictory. With or without a stiff ►



PHOTO: DAVE CHAPMAN

can only be an impediment to the uninhibited expression of the emotions. And the further you get from the emotions, the more you depart from the path of righteousness. Only the immediate emotional spasm has the mark of authenticity and truth, because only it is untainted with what is most hateful to the new religion—intelligence. How appropriate that the first saint of the new religion should be a woman who, by her own admission, was 'as thick as two short planks'.

The week between Diana's death and her funeral was like a vast Oprah Winfrey show in which mourners competed to show the devastation they felt at the loss of the

a course of therapy in order to show them the true light.

In the hierarchy of virtue, it is those who feel most immediately and most intensely who have access to the highest truth. The holy ones of the new religion are those who suffer most—the homeless, Aids victims, or those with eating disorders. However, because these holy ones feel the world so intensely they have great difficulty in making their suffering understood by the rest of us. That is why they need so many interpreters to pass on their wisdom and the deeper meaning of their suffering. It was these interpreters—sometimes known as charity workers—who took pride of place at the

◀ upper lip, it would have been difficult to convey the many layers of emotion while at the same time keeping pace with the frenzy of grief sweeping the country. In the circumstances, it is not surprising that they decided to stay put in Balmoral and look at the trees.

What they failed to realise is that when grief and mourning are demanded, complex emotions are not allowed. Complexity implies an element of thinking and reflection which can only pollute the pure goodness of feeling. That is the vilest sin for the new religion.

It is ironic that for all the emphasis placed on the authenticity of feeling, anybody who did not want to be a part of the *Oprah*-style show was pressurised to put on a bogus show of emotion. The casual disdain for true feeling was matched by the militant insistence of many to parade the authenticity of their own emotions with all the paraphernalia which has become so familiar—the flowers, the teddy bears and the mawkish inscriptions. It is because the grief was so staged and so shallow that it could quickly turn to self-righteous anger. As with Dunblane, it was not long before national grief turned to grievance, and grievance to vengeance. That the royal family could become a target for popular hatred in the space of a week is a chilling reminder of the power of the new emotionalism. How would somebody less well-established in popular affections fare if this sort of venomous witch-hunt was turned on them?

The public bitterness is further compounded by the strong element of self-loathing in it all. It is only possible to make somebody like Diana look so saintly if there is a simultaneous belief that the rest of us are in the gutter. Diana was too good for us sinners. Add to that the widespread belief that we are all responsible for her death, because we bought the tabloid newspapers which exploited her image, and you have a lethal cocktail of self-hatred.

The greatest myth of all about the sanctity of feelings is that they are above politics and political manipulation. Nothing could be further from the truth. It is precisely when people cast aside their critical faculties and give themselves over to the free flow of emotions that they are enslaved to forces beyond their control and become fodder for manipulation. Tony Blair's lip-quivering performance on the day of the accident was hailed as a perfect response for the heartfelt spontaneity with which it captured the mood of the nation, and was contrasted with what might have been if John Major was still in power. It turned out later that Blair had gone through the performance beforehand down to the last detail with his press secretary Alistair Campbell. Manipulative politicians can only thrive on the primacy of feelings. ●

# THE NEW PROTOCOL

Brendan O'Neill

*'Now we know', she said, 'that the royals are as frail as the rest of us'*

'White people in this country do not really understand what Princess Diana stood for. As a black man I know what it is to be an outsider and Diana was the ultimate outsider. She was a caring and passionate woman in an outdated and screwed-up establishment.' Raymond, a 26-year-old choreographer from Hammersmith in West London, was sitting in a deckchair chained to the railings on The Mall. With less than 24 hours to go to Princess Diana's funeral Raymond said he would brave 'rain, hail, sleet and snow' to bid farewell to his 'personal princess'.

Next door to Raymond was Myra, a 62-year-old grandmother from Surrey. 'I am a

well.' Everybody agreed. Marcia, a student from south London, said: 'Now we know the royals are as frail as the rest of us. It is important for the sake of the two princes that they don't bottle up their grief.'

After years of seeing the Queen on TV, looking down her nose at the rest of us, I was struck by the informality of her impromptu appearance. One reporter said it looked like the Queen was becoming more 'Diana-like'. Another, speaking into a microphone, said, 'At last, the stiff upper lip is giving way to a quivering lower lip'. Everybody I spoke to was pleased to see the Queen; not because they felt privileged in the presence of the head of state and



PHOTO: DAVE CHAPMAN

passionate royalist', she explained from her makeshift tent, 'but I feel so ashamed every time I look towards Buckingham Palace and see that they still haven't lowered the flag to half-mast. All we want is a sign that the royals are suffering like the rest of us'.

Further on, at St James' Palace, Amy, a housewife and mother-of-two from Kent, was pinned up against the railings. 'There are rumours that the Queen is going to come out and talk to us', she explained. Five minutes later the Queen and Prince Philip emerged from St James' Palace and began chatting to the mourners. Amy handed the Queen a single rose and offered her condolences. Tears were welling in her eyes: 'That is all we needed', she said to me afterwards. 'Just to know that the Queen is hurting as

defender of the Anglican faith, but because the Queen had demonstrated that she too is flawed and might be in need of some Diana-style love and understanding herself.

It struck me that Raymond and the other mourners were wrong: Diana was not an outsider. She was an ambassador for the new establishment as much as Queen Elizabeth was for the old. The real outsiders today are the royal family themselves with their old-fashioned protocol and their arrogant belief that they can cope with their grief on their own, in private. Diana's legacy is a new protocol which demands that you demonstrate your fallibility in as public a manner as possible, and prove that you are as pathetic as 'the rest of us'. ●



# TRAGIC LIVES

**Ann Bradley**

*'Diana's death was of her making—as was her life'*

Everybody tells me that Princess Diana led a 'tragic' life. Why? A cursory consideration of the life and death of Diana gives the lie to her famous vulnerability and victimhood.

Consider the circumstances of her death. First we had Di as victim as the paparazzi, then Di as victim of drunken chauffeur egged on by paparazzi. In reality the culpability for the accident seems to have lain fairly and squarely with those who died in it—all of them, not just the driver. Chauffeurs are not known for careering along at idiot speeds if their employers protest.

Since when has the 'threat' of being photographed been accepted as an excuse for hurtling through the middle of Paris at more than 100mph? A threat of gang rape might have justified it but photographers...be serious. Commentators were quick to demand of the photographers whether they really felt their pictures were worth the carnage. It might have been more appropriate to pose that question to the spirits of Di and Dodi. Did they think avoiding having their pictures taken was worth the carnage? Not to mention the even greater tragedy that would have been caused had any of the good citizens of Paris been going about their business in the path of the maniacs in the Mercedes. I only hope the millions deafening their gods with prayers for Di and Dodi are giving thanks that the loss of life was so limited.

No, Diana's death was of her making—as was her life. Yet, as we are told she was a victim in death, so we are told she was a victim in life.

Sorry, but I cannot see it. Yes, she was in the public gaze. She chose to be. Future



PHOTO: EMMA RIDGMAN

Kings are not noted for their low public profile—nor are their wives. Yes, she felt isolated among hostile in-laws. So do many women. Yes, her husband cheated on her. This is what husbands sometimes do, and most women survive it. In fact, Diana survived it and found a lover of her own.

While the nation is being carried away on a tide of mawkish sentiment and rewritten history we should remember what Di's life was really like. She was an aristocratic socialite who enjoyed high society, an endless supply of designer frocks, amusing companions and ritzy holidays. The 'good works' for which she has been canonised were a nineties version of the part-time charitable deeds which ladies-who-lunch have pursued for generations, and which have never interfered with a luxury lifestyle. Her personal disappointments should have

been offset by the fact that she had two healthy sons whom she adored, she was fit, attractive and healthy, and always able to buy a degree of independence. This is not a tragic life, it is a privileged life.

Reflect on this for a moment.

I know a woman who at the end of the Second World War was forced to leave her own sister dying in a ditch as she was marched away from a concentration camp by Nazis trying to avoid capture by the Americans.

I know a woman who after several years of infertility had a successful IVF pregnancy which ended in the birth of a severely brain-damaged child.

I know a man who lost both his legs in an industrial accident and who, when asked if he ever wondered 'why me?', replied in genuine bemusement, 'why shouldn't it have been me, why should it have been someone else?'

These are people who have endured true tragedies, yet none would accept that they were tragic figures or had tragic lives. Nor would they thank you for your pity, but resent the implication that their lifetime's achievements were less important than the sad events they have experienced. Those who genuinely suffer rarely do want to wallow in their personal tragedies—they just want to get on with it. 'It' being life, despite all it has dealt them.

Out of all of the millions who have shed tears for Diana many will have themselves lived harder lives and known others who have died harder deaths. I would rather save my tears for those who deserve them. ●



PHOTO: DAVE CHAPMAN

## ME AND MY MEMORIES

As a subscriber to *LM* and someone whose wife is severely disabled with CFS (ME), I feel duty bound to respond to Mike Fitzpatrick's book review ('The spirit of Salem goes global', September). His position on this illness is ill-considered, and simply mimics that of the psychiatric profession who have caused so much harm to sufferers.

It is shocking to find a Marxist claiming that it is useful to accept that CFS is 'hysteria', rather than striving to find a medical explanation for the symptoms. There is now hard evidence that CFS is an acquired immune system dysfunction. Take a look at the new medical data, or Suhadolnik's work showing the wide-ranging and devastating effects of the disruption to the RNaseL anti-viral pathway in CFS sufferers.

Showalter's 'hysterical' explanation is no more than crude mysticism cloaked in psychiatric terminology. Psychiatry has a long and discreditable history of claiming unexplained illnesses as its own. Only a few decades ago, patients with multiple sclerosis or infantile paralysis (polio) were sent away to mental hospitals, diagnosed with 'hysterical paralysis'. TB was once considered a condition 'suffered by morose people of a poetic bent'. These outdated voices are lent support by Showalter. Her thesis fits in perfectly with the current anti-scientific ideological climate.

**RUSS** *London NW2*

Mike Fitzpatrick is quite wrong to dismiss the memories of adults who were abused as children as merely a symptom of an anxious age. He quotes Mark Pendergrast's example of the Holocaust survivors who have never repressed memories of their experiences, as evidence against the possibility of such repression. Yet why should Marxists have such a problem with this phenomenon, when its key aspect revolves around the *social acknowledgement* of the experience? Whilst Holocaust survivors had their experiences confirmed by each other and by the vast majority of the rest of the world, abused children have only recently been able to rely on such acknowledgement.

Libby, the woman who was raped aged 16 and interviewed in the same issue of *LM* ('Aren't I allowed to be all right?', September), says: 'at the time all I wanted to do was pretend it hadn't happened.' Now imagine a younger child, whose attacker is her father, in a situation where the other members of the family refuse to acknowledge what has happened. What would she do other than deny the reality of the experience?

*LM* has correctly noted that it is not the scale of child sexual abuse which has increased in recent years, but the awareness of it. Where does Fitzpatrick think the people who were abused before the current awareness have gone to? Is he intelligent enough to see that they have grown into independent adults who for the first time have the opportunity to speak the truth? That the current awareness of child sexual abuse feeds into today's 'culture of fear' is a regrettable consequence of contemporary political circumstances. It does not alter the reality of that abuse.

**LESLIE SMITH** *London W8*

## DIANA AND THE PAPARAZZI

As in most European countries, Italy responded to the death of Princess Diana by rescheduling TV programmes and saturating the media. But the role of the photographers was of particular interest in the home of the paparazzi. The term paparazzi originates from Federico Fellini's film *La Dolce Vita* (1960) about a photographer, Signore Paparazzo; it has been widely used in Italy for decades to describe over-zealous photographers.

The liberal-left responded by blaming the paparazzi. However, they simultaneously acknowledged the responsibilities of their own media and readers. *L'Unita*, the socialist newspaper of the co-governing PDS, headed its front page of 1 September with 'Scusaci, principessa' (saying sorry using a form of address usually reserved for close friends). Those on the right have tended to be less critical of the media. Vittorio Feltri, editor of the centre-right newspaper *Il Giornale* called the

'Scusaci, principessa' article 'a nonsense because the facts prove the hypothesis of the drunk driver'.

Giuliano Ferrara, a member of Silvio Berlusconi's right-wing Forza Italia, wants to buy the pictures of Diana and Dodi dying and publish them in the magazine he edits, *Panorama*. He believes 'these pictures are too important to take them away from the readers'. But the publishing company which owns *Panorama* has refused to try to buy the pictures.

More widely there is a sentiment that the paparazzi and the media should reconsider their roles and exercise good taste. But there is a misconception that this kind of decency already prevails in Britain's broadsheets. Enrico Deaglio claims 'in Britain as in Italy there is an abundance of gossip tabloids, but then there is another category of journalism. This deals with serious matters and does not stab people in the back'. Perhaps Deaglio should have followed the *Guardian* campaign against Neil Hamilton, or the various broadsheet stories about the sex lives of bishops and invasions of killer insects.

**DOMINIC AND LAURA STANDISH**

*Treviso, Italy*

At my workplace most of the deep shock and grief was saved for the untimely death of the Liverpool v Newcastle match. This game could have lived on and blossomed into something truly beautiful. As it is, I am left holding a wreath at the Shankly Gates. Surely the FA realises that football is not a matter of life and death; it is more important than that.

**PAUL BRYAN**

*Birmingham*

## ABORTION HISTORY REPEATS ITSELF

Reading Beth Adams' article ('What's the problem with lunch break abortions?', September) I wondered what all the fuss is about. Back in 1978 the trades council, of which I was secretary, was approached by a gynaecologist from Tameside General Hospital, a Mr Goldthorpe, who complained that Manchester's chief constable James Anderton was preventing him from offering 'menstrual aspiration'—a simple form of early

abortion 'carried out in the patient's dinner time'. Do we constantly have to re-fight earlier battles, just to keep in the same place?

**DAVE HALLSWORTH**

*Ashton-under-Lyne*

## GENES AND INTELLIGENCE

It would be interesting to hear Dr Stuart Derbyshire ('The sense we were born with?', July/August and *LM-mail*, September) explain what form of cognitive process is contained by a genetic factor and how this biological event is related to mental content. Does it occur maybe in the pineal gland? Or would it be more reasonable to suggest that cognitive processes are not divisible from their very social content. Derbyshire seems to acknowledge this difficulty but unfortunately resolves it by speculating that there is a genetic component to knowledge.

It is difficult to escape the conclusion that, in his correlation of genetically influenced 'cognitive ability' with 'more traditional measures of excellence including academic and job performance', he is suggesting that there is some natural basis for these phenomena. Would he like to go further and suggest that the vast majority in dead-end jobs are there because they are not genetically up to scratch?

Perhaps he would like to consider that career and academic position tends to be the preserve of the privileged middle class, and that any relation to high IQ might suggest that this is also a result of the increased mobility and access that privilege brings. It is hardly surprising that this area is so heavily researched; what better defence of privilege can there be than that it is natural?

**MICHAEL LESTER** *Nottingham*

Stuart Derbyshire misses the point of James Heartfield's article ('A fool's errand', July/August). Not only is intelligence not a fixed or natural property, it is also qualitatively different from all physical characteristics. As a result, Heartfield argued, it is a 'category error' to look for the relationship of genes to intelligence. The two cannot have a relationship because

human consciousness develops in opposition to the realm of instinct and predetermined behaviour. Babies lose even the most basic instincts that they are born with before they re-learn those skills and reactions. The development of physical skills (eg, balance, manual dexterity, eye focusing) may have an impact on the development of the personality, thereby indirectly affecting skills that are measured in IQ tests (which should not be equated with intelligence). But consciousness is a problem-solver which, like a universal Turing machine, starts as a blank sheet and only develops on-the-job.

**SUKE WOLTON** *Oxford*

### WHO CARES ABOUT DEVOLUTION?

If anyone was looking for a high-level public debate about Scottish devolution, the Edinburgh Book Festival would surely be the place to find it. In the event, Scotland—A New Dawn, was an engaging hour and a half with four relevant authors, but somehow a sense of frustration is never far from the surface in any discussion of devolution, and this was no exception.

While most Scots reportedly support a Scottish parliament, the real dynamic for devolution is coming from the political establishment. Westminster's lack of credibility, coupled with the new government's desire to reorganise welfare and other institutions, would seem to be more substantial factors than the Braveheart sentiment, in the creation of the Scottish parliament. If we begin by recognising this, we can drop the phantom liberation debate and get to grips with what is really happening in Scottish politics.

**DOLAN CUMMINGS** *Glasgow*

### GAY PREJUDICE

Paul Briggs (LM-mail, September) is right to say that the faults I found with the 'gay community' in my Pride piece ('Almost ashamed of Pride', July/August) are also shared by wider society. But my point was that in a sense the gay community had them first. Many of the ideas and prejudices most paralysing to the project of change can be traced back to the radical and liberationist



circles of the 1970s and 1980s such as the women's and lesbian and gay movements.

Homosexuals tend to experience their difference from the mainstream in the highly privatised and individualised sphere of sexuality. It should not be surprising, then, that gay political expression has traditionally been individualistic, with the emphasis on coming out, reinventing your life, self-image and so on. And again, for both women and gay men the threat of violence from people likely to be more powerful than you is very much part of the experience of oppression. So it is not surprising that concerns about danger and safety became prominent in the organised liberation movements.

In the past few years similar conditions to those in which such concerns took root have come to prevail across wider society. Social life as a whole has become more individualised and privatised, and wider shifts in ideology have moved the threat of violence and other forms of physical danger into the spotlight of mainstream concern. At the same time many of those reared in the radical environment of the 1980s have become influential establishment

figures. So ideas that first grew among certain sections of society have achieved a much wider currency.

None of this was inevitable: reactionary ideas that appear to correspond with people's experience can always be challenged with convincing alternative explanations. Individualist politics flourished in the liberation movements of the past, partly because the old Left failed abysmally in finding an adequate response to racism, sexism and homophobia. Today the whole of society is at an ideological impasse, with traditional alternatives to capitalist democracy discredited and with many erstwhile radicals and progressives now the strongest advocates of the new authoritarianism.

As to Andrew Cox's questioning (LM-mail, September) why I bother turning up for Pride at all, well, as I said in my piece, it is a bit like Christmas. As an atheist and opponent of family values, I loathe the whole idea of Christmas, but like many who share my view, I often end up participating because those close to me do and it seems churlish, not to mention lonely, to leave oneself out. As it happens, this year

I rather I enjoyed myself at Pride.

**DES DE MOOR** *London SE14*

### NZ TO LM

This is to inform readers of *LM*, especially in the Asia-Pacific area, of a new Marxist magazine produced in New Zealand. *Revolution* began publication in April and comes out every two months. It aims to examine contemporary trends from a Marxist perspective relevant to our times, rather than simply repeating the slogans of the 1930s.

The fourth issue (Oct/Nov 1997) is a special feature on the death of NZ politics which will look at the shift of all the political parties to the centre-ground, the rise of Maori nationalism, the remaking of NZ national identity, political correctness and social control, the demise of feminism as any sort of coherent social movement, and other trends here. Subscriptions to the US are \$NZ39 (airmail), \$33 (surface); to Europe \$NZ42 (airmail), \$36 (surface). Rates for Australia, Asia and the Pacific are available on request from Radical Media Collective, PO Box 513, Christchurch, New Zealand, or by e-mail: plf13@pophost.canterbury.ac.nz  
**PHILIP FERGUSON**  
*Revolution* magazine

## The what's NOT on guide

The what's NOT on guide is itself not on this month. This is because it would take an entire issue of *LM* to list what was taken off 'as a mark of respect' to Princess Diana.

## WE WELCOME READERS' VIEWS AND CRITICISMS

Write to The Editor, LM, BM InformInc, London WC1N 3XX fax (0171) 278 9844.

Letters may be edited for clarity and length

# TABOOS

*Why do more women now choose not to have children? Perhaps because more people today lack confidence and fear commitment, says Ann Bradley*

## THE CASE FOR KIDS

**W**hen demographers talk about the 'baby gap', they don't mean a high street store which sells cute but over-priced clothes for kids. They are talking about the growing trend for the twenty-somethings, and increasingly the thirty-somethings, not to reproduce. While motherhood has long been seen as a normal, even inevitable, part of a woman's experience, it is now eschewed by an increasing number who prefer to remain 'child-free'.

Statistics show that whereas 90 per cent of women at the peak of their fertility in the 1960s would have a child, among women of the same age today between 20 and 25 per cent will remain childless. The latest edition of the regular report by the Office of National Statistics Population Trends concludes that, assuming involuntary infertility has not changed much, the figures suggest that childlessness by choice has increased sharply.

'Childlessness by choice' is a concept that number-crunching demographers have taken some time to accept. The decline in births to women in their twenties has been a feature of official statistics for some time, but this trend was (and still is) accompanied by a rise

in births to women in their thirties. This has led many of the discussions to focus on women's desire to defer motherhood rather than avoid it altogether. When, in the early nineties, it was first suggested that the number of childless women was growing, the received explanation was that many were women who had intended to reproduce but had deferred so long that their biological clock had run out.

This may well have been the case for some women. For more than a decade there has been a well-documented trend for women to postpone the birth of their first child until their late twenties. The reasons are not very difficult to

grasp. The far greater involvement of women in the workforce provides a powerful incentive to delay pregnancy. For working class women, the expansion of women's jobs has offered the chance to earn an income. For middle class women, the explosion of job opportunities has meant the chance to establish a career. Consequently it is not surprising that the proportion of employed women in their late twenties has shot up from 61 per cent in 1984 to 72 per cent in 1994. Demographers project this proportion will hit 80 per cent by 2006. As any working mother will admit, combining work with child, given the paucity of affordable

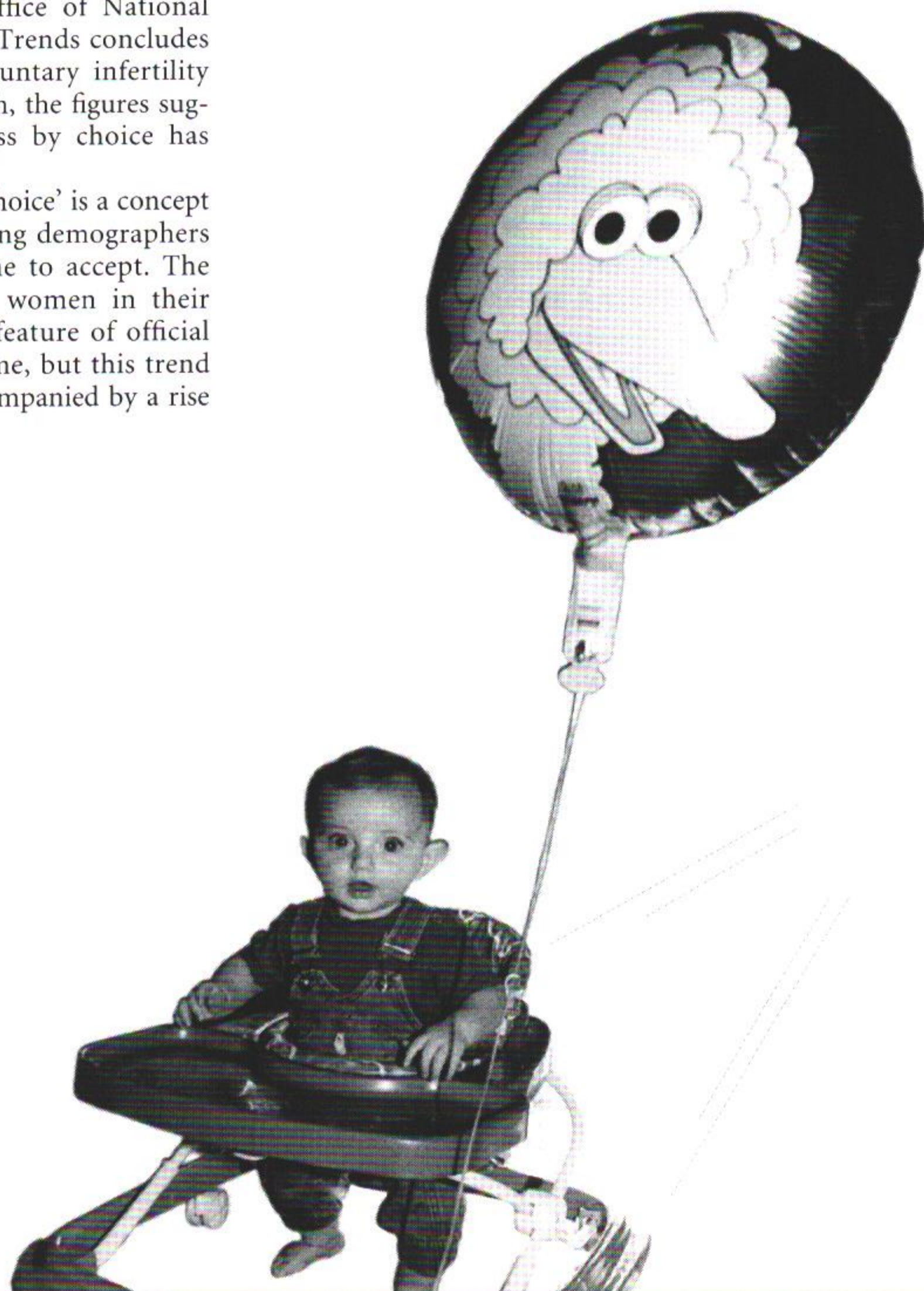

childcare, is no easy task, and it is clear that many women feel that child-bearing will have to wait.

Family planning organisations have pointed out that more women are possibly postponing births simply because they can: a desire to postpone a first birth is now far more practical than in the past. The wide range of effective contraceptive options, and the relative ease with which women can now obtain abortion when contraception fails, means that women are more in control of their fertility and able to plan their families according to convenience. Furthermore the improved sophistication of tests to detect fetal abnormalities has given some women the confidence to risk the increased likelihood of abnormalities associated with pregnancy later in life.

However, recent population profiles suggest that there is more to it. Women are not simply postponing motherhood, but rejecting it altogether. This is well illustrated by the number of couples opting to be sterilised well before the 'natural' end to their reproductive years. Despite the expansion of the range of reversible contraceptive options over the last 20 years, recent research published in the *British Journal of Family Planning* shows that the number of couples relying on female sterilisation has doubled to 13 per cent, and those relying on vasectomy has almost tripled from five per cent to 14 per cent. Furthermore, women's health clinics outside the NHS, such as those run by the Marie Stopes organisation, claim that their sterilisation clients are getting younger. Whereas the operation was once seen as something a couple considered when they had completed their family or when a woman in her mid-thirties came off the pill, now it is increasingly requested by childless career women in their twenties who have better things to do than parent.

Given the debilitating effect a child can have on a woman's engagement in

the outside world, it is unsurprising that some feminists have seen this as a positive development. And in some ways no doubt it is. Countless thousands of women over the years have born children out of obligation rather than willingness—reluctantly and resentfully succumbing to motherhood, rather than embracing it with enthusiasm. If women are now able to make a genuine choice about their fertility it is only to be welcomed. Who can count how much female potential has been squandered in domesticity?

But listening to the voices of some of the women interviewed recently in media discussions of the issue has left me feeling uneasy. In the past, when a woman rejected motherhood she rejected traditional conservative values about her 'natural' role. The decision to remain child-free was a decision to break away from the dominant assumption that maternity must be a woman's highest ambition. Today, by contrast, the reasons given for not having children often seem to echo contemporary conservative sentiment. The decision to remain childless seems for some not to defy society's expectations, but confirm them.

Today we live in a society characterised by fears and insecurities about the future, caution about commitment, obsessive concerns about the adequacy of parents. These are themes that

constantly appear and reappear in the media debate. The reasons why many couples are opting to remain child-free reflect many of these concerns. A plummeting birth rate is a typical feature of a society in which the population feels insecure and rootless—which is why it is a major current concern in the countries that made up the former Soviet Union. But the fashion for childlessness in Britain seems to represent something more: an absence of confidence, not just in society, but in one's own self.

Consciously deciding to have a child represents everything that many young middle class people seem to wish to avoid. It represents a commitment to and responsibility for another person for the indefinite future. It represents a self-confidence in your capacity to cope physically, emotionally, intellectually, financially and organisationally with something that is unknown and unquantifiable—unlike a car, you cannot test-drive an infant to see how you will get on. It also represents a declaration that you are willing to make a change from the life you know (of friends and parties) to one that seems unimaginable (dirty nappies and broken nights). In short, the decision to have a child means saying: 'I don't know how this will change my life, but I know I can handle it.' This is a sentiment that, in the nervous nineties, seems in short supply. ►

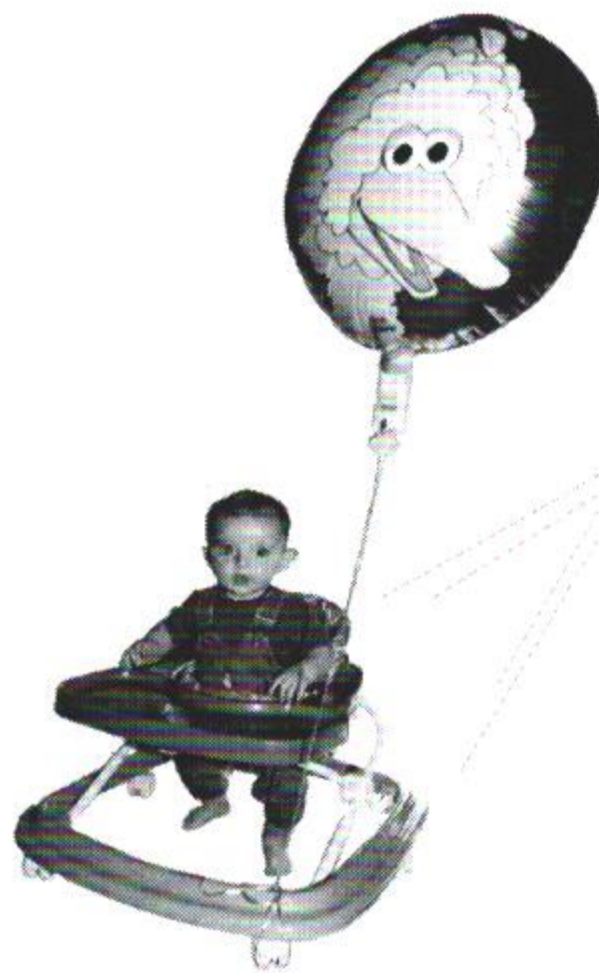
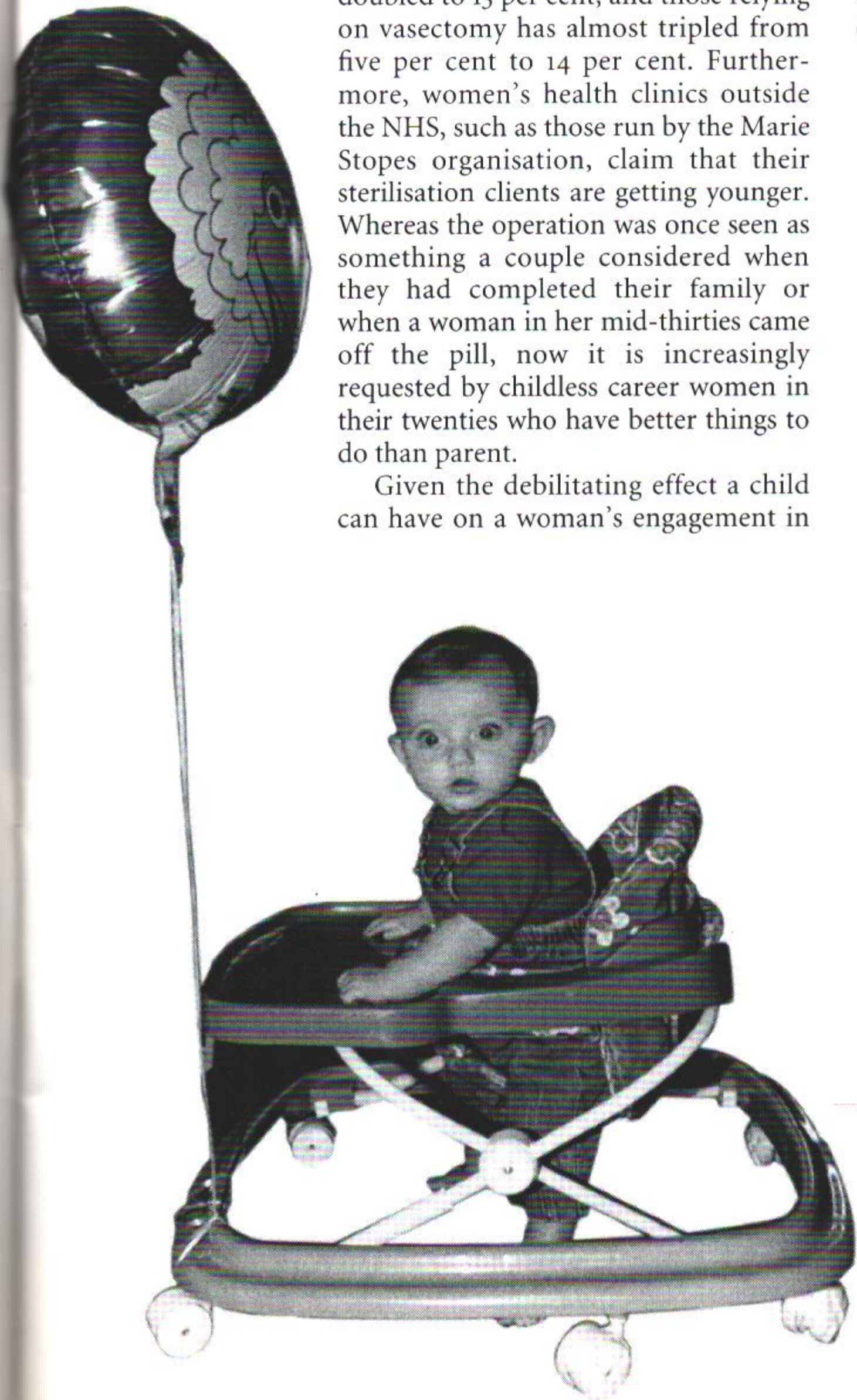

# The decision to remain child-free can be an act of extreme conservatism.

◀ For some couples, the decision not to have a child is a calculated, rational and sensible desire to focus on another worthwhile goal. But for others it fits less into the framework of heady aspirations, and more into a context of

destructive self-doubt. For these people, childlessness seems to be the 'couples equivalent' of the student who returns to his parent's home every vacation and moves back into his old bedroom when he graduates—still hanging on to the past, afraid to take up the challenge of an independent life in case he fails. The decision to remain child-free can be an act of extreme conservatism.

Of course, it would be wrong to suggest that the world is divided into the adventurous who reproduce and the unadventurous who don't. The decision

to have a child can certainly represent a desire to retreat into the personal pettiness of private family life. For some, emotional investment in a child represents an end to your own personal ambition for oneself, a drawing back from the challenges of life. It can represent the passing of the torch to a new generation in a way that implies that the current one has gone as far as it can go.

But it does not have to be like that. Having a child can represent a creative, forward-looking desire to reproduce in your own image: to replicate your strengths and ambitions and have a say in the future.

It seems a sad society when an increasing number of people feel no motivation to take a newly born human and try to shape it into a person in their own image. It seems a little pitiful when people feel no impulse to create a new generation and teach them to value the qualities they value and fight for the goals they feel are worth fighting for. A society that avoids commitment is surely a society without convictions. ●



PHOTOS: STELLA HUME BY DAVE CHAPMAN

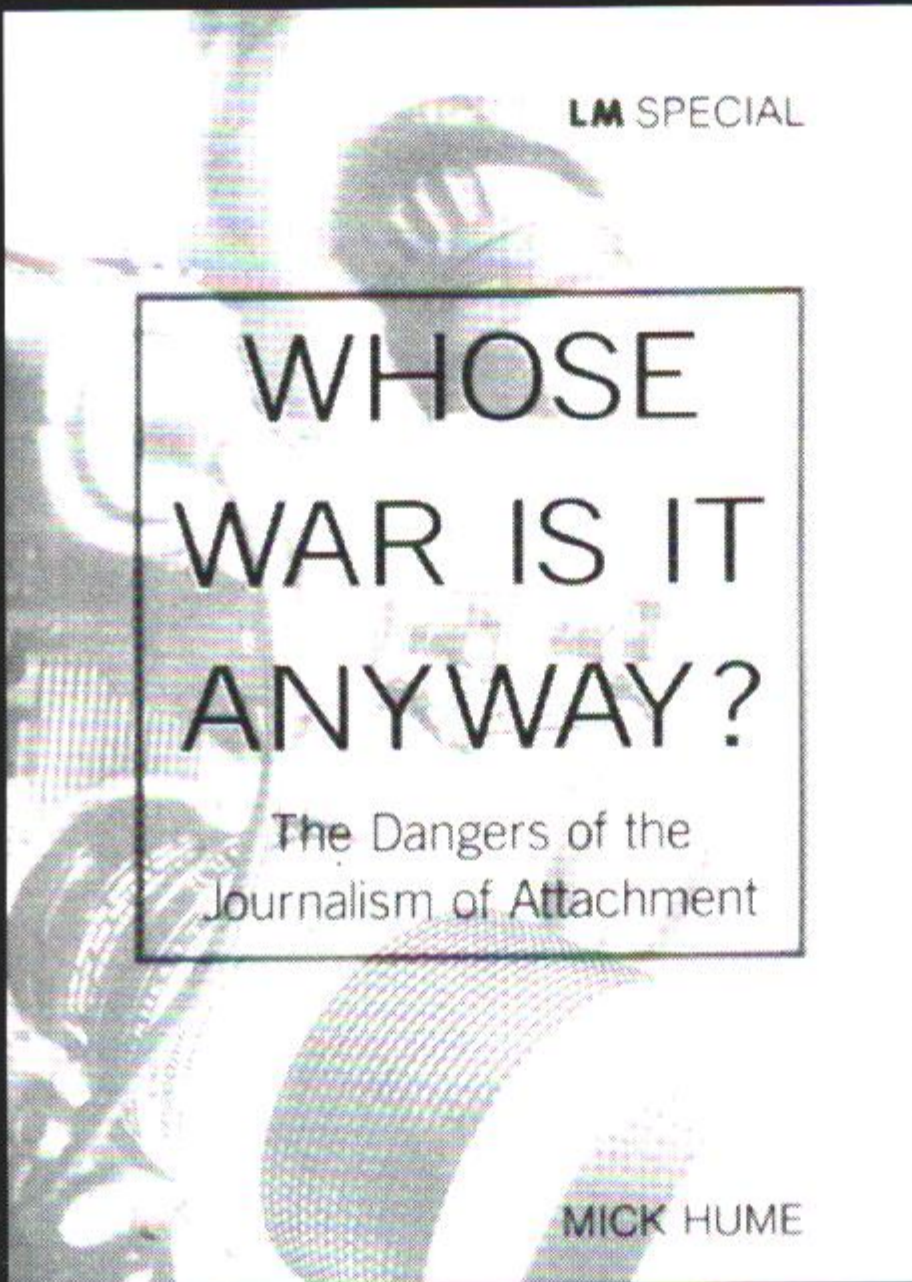

At a time when many in the West are unsure about the meaning of right and wrong, war reporters are trying to re-establish some moral certainties in relation to faraway places. In launching their mission to vanquish 'evil' in Bosnia or Rwanda, they are using other people's life and death conflicts to work out their own existential angst, turning the world's war zones into private battlegrounds where troubled journalists can fight for their own souls by playing the role of crusader.



**LM**SPECIAL  
**WHOSE WAR IS IT ANYWAY?**  
 The Dangers of the Journalism of Attachment  
 MICK HUME

£5

(add 75p for postage and packing)  
 Make cheques payable to JP Graphics, and send to  
 JP Graphics Ltd, BM JP Graphics, London WC1N 3XX

At a time when many in the West are unsure about the meaning of right and wrong, war reporters are trying to re-establish some moral certainties in relation to faraway places. In launching their mission to vanquish 'evil' in Bosnia or Rwanda, they are using other people's life and death conflicts to work out their own existential angst, turning the world's war zones into private battlegrounds where troubled journalists can fight for their own souls by playing the role of crusader.

*As the media is accused of 'hunting' Princess Diana to her death, the demand grows for some kind of a privacy law to protect the rights of people in Britain. Helen Searls argues that such legislation threatens to undermine some of the few freedoms we have left*

## THE RIGHTS AND WRONGS OF PRIVACY

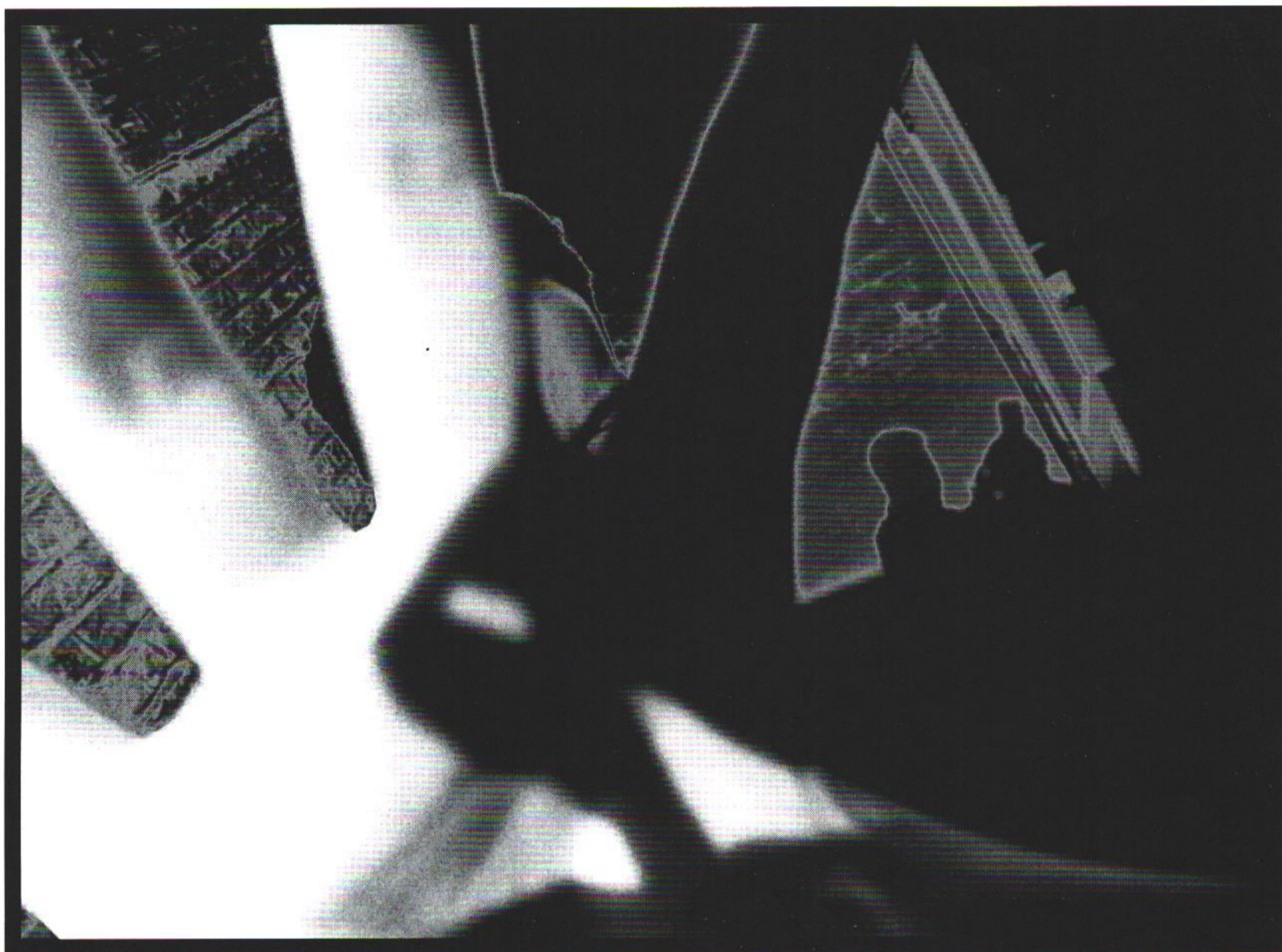

Lord Irvine, Labour Lord Chancellor, is due to introduce a bill to incorporate the European Convention on Human Rights (ECHR) into British law. One section of the convention—Article Eight—will attract particular attention in current circumstances. It states that 'Everyone has the right to respect for his private and family life, his home and his correspondence'.

When the Article was first framed in the late 1940s, with the experience of fascism fresh in the mind, it was presented as a measure to protect people from the intrusive power of the state. In 1997, however, lawyers, politicians and journalists credit it with a different meaning. Article Eight is today widely interpreted to mean that people should now be protected from press intrusion into their private lives.

The long-running controversy over the press and privacy has become more heated in recent months. When the *News of the World* revealed that Robin Cook, the Foreign Secretary, was having an affair with his parliamentary assistant in August, Lord Irvine recommended that parliament introduce its own privacy law rather than wait for judges to interpret the ECHR. The calls for privacy legislation reached a new peak in September, after the press was blamed by many for hunting Princess Diana to her death.

Of course, the press has been threatened with privacy legislation before, notably in 1993 after the tabloids published transcripts of inane phone calls which revealed that Diana had the pet name 'squidgy' and Prince Charles dreamt of being a tampon. Today's debate, however, differs in one important respect. ▶

*Guardian* editor,  
**ALAN RUSBRIDGER,**  
 has even led the way in  
 calling for a  
**PRIVACY LAW**

◀ In 1993 the call for a privacy law was met with opposition from the press and civil rights campaigners. Broadsheet and tabloid editors recognised it as an attack upon press freedom and orchestrated a campaign of resistance. In 1997 the opposition to a privacy law is weaker. Some of the old opponents have even swapped sides. John Wadham, director of the civil rights group Liberty, now says that 'journalists have nothing to fear' from the proposed legislation (*Guardian*, 4 August 1997). Alan Rusbridger, *Guardian* editor, has even led the way in calling for a privacy law. Andrew Marr, editor of the *Independent*, Richard Addis, editor of the *Express*, and other leading journalists have publicly voiced their agreement with him.

DESPITE THE FURORE SURROUNDING THE paparazzi's alleged role in Diana's fatal crash, there is no evidence that the media has been getting more intrusive into people's private lives. Tim Toulmin from the Press Complaints Commission (PCC), the industry's self-regulatory body, told me that only about eight per cent of all of the complaints that the Commission receives relate to matters of privacy. Most of these complaints are about regional newspapers rather than the national tabloids. And although Toulmin assured me that the PCC is 'especially concerned' about unwarranted press violation of personal privacy and treats complaints in this field more seriously than those in any other, the vast majority of privacy complaints are not upheld.

You could argue that as a self-regulatory body, the PCC would say that, wouldn't they? But there is other evidence that they are right. It is widely recognised that the press has become more restrained in recent years, tightening self-regulation in order to ward off the threat of government legislation. So why do so many now favour privacy legislation?

Alan Rusbridger's own explanation for his recent conversion is unconvincing. In his view the courts, the government and media need to do a little horse-trading in order that 'responsible journalism' can flourish and prurient intrusion is punished. This could happen if the three parties concerned make concessions. It would mean, says Rusbridger, 'The courts giving a little on defamation. The government giving a little on freedom of information. And the media giving a little on intrusive journalism' (*Guardian*, 23 May 1997).

Rusbridger claims that a privacy law which allowed the press to investigate financial impropriety, but prevented it from reporting sex scandals and other personal matters, would do little to hinder serious journalism and might even raise the standard of investigative journalism in this country. The idea that a privacy law of any kind could raise the





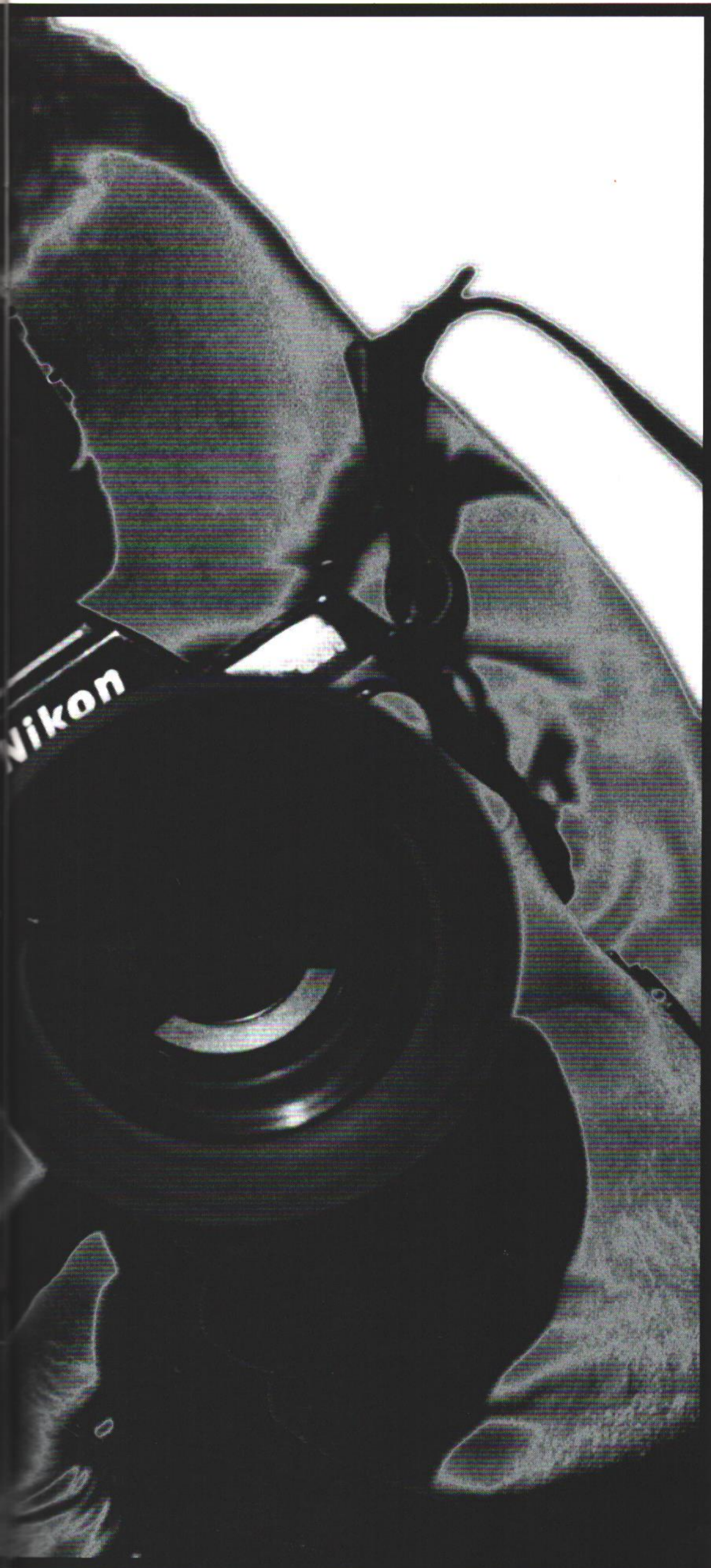

Experience should  
tell us that trading  
a privacy law  
for a bit more  
leniency in the  
**LIBEL COURTS**  
would get us nowhere

standard of investigative journalism is the kind of contorted logic that one might expect of lawyers but not from the editor of a national newspaper. Experience should tell us that trading a privacy law for a bit more leniency in the libel courts would get us nowhere. Journalists have long argued that this would simply replace one law that the rich can use to silence their critics with another.

Investigative journalist Tom Bower, Robert Maxwell's biographer, is one who says he would never want to rely on a judge to decide what could be printed. His own experience indicates that privacy laws could be even worse than libel laws. Tom Bower spent years in the libel courts fighting for the right to publish his book exposing the nature of Maxwell's business empire. On four occasions Maxwell tried to prevent the book's publication through use of the British libel law. He ultimately failed. In France, however, where there are tough privacy laws, Maxwell successfully sued Bower. His hard-hitting investigative book was deemed to breach privacy for revealing correct details about Maxwell's ailing health.

Rusbridger is simply kidding himself in imagining that a privacy law would allow investigative journalism to flourish. He imagines that all the problems in journalism lie with the tabloid press. He laments that the libel courts do not distinguish between the thorough investigative journalism into areas of public concern (ie, the *Guardian*) and salacious stories about minor celebrities (ie, the tabloids). A privacy law with what he calls a 'sex/money split' would, he argues, allow them to make such distinctions.

THE TABLOIDS HOWEVER CANNOT BE MADE TO carry all of the blame for the demise of serious investigative journalism. For a 'quality' paper like Rusbridger's *Guardian*, investigative journalism has been reduced to reporting the rather boring minor financial misdemeanours of yesterday's politicians. Fine, if that is all that they want to do; but it hardly justifies Rusbridger's holier-than-thou demand for a privacy law.

At present several different issues are being mixed up in the discussion of the press and privacy, which makes it hard to work out what is really at stake. Liberty for example insists on confusing issues of personal protection from state intrusion—which are perfectly reasonable—with issues of restricting the press—which are not. The debate is also muddled by the fact that today it seems that the only staunch opponents of a privacy law are a few journalists of the old school like Tom Bower and tabloid editors and gossip columnists.

The arguments for and against a privacy law are often caricatured as the interests of 'respect and decency' against ►

◀ the naked commercialism of the tabloid press. Press freedom is reduced to little more than the right of tabloid journalists to spread scandal unhindered and the rights of newspaper owners to print whatever copy or pictures sell the most papers. If opposition to a privacy law is reduced to merely supporting the rights of the tabloids to pry in a sensationalist fashion into people's private lives, then it is little wonder that support for a privacy law is growing.

Defending press freedom, however, means a lot more than this. In defending his call for a privacy law Rusbridger rather sanctimoniously asked do we really need to know about the sex life of a weather forecaster? While some might argue that depends on which weather forecaster, of course Rusbridger is right, we would be no worse off if we knew nothing about the sex life of the weather forecaster. But that is not the same as saying that we would be no worse off with a privacy law that prevents the press even looking into this question. The two things are not the same at all.

A privacy law would undermine the freedom of the press and the important right upon which that freedom is founded—free speech. These freedoms are continually undervalued in the debate. A privacy law would demarcate whole areas and issues as being 'out of bounds' to public discussion. This is a potentially dangerous restriction on freedom and democratic debate.

DISTASTEFUL THOUGH IT MIGHT SOMETIMES BE, we need the right to discuss people's personal lives. This is not just a right for the titillation of a few journalists and their readers. It can benefit society as a whole, since it allows us to partake in the fullest and frankest debate possible on any issue. To rule that only certain things could be reported means that the parameters of public debate are already constrained even before the discussion begins.

Public figures in fact often invite us to look at their private lives when it suits them. In many instances their only complaint is that we catch sight of things they would rather we did not see. But on other occasions they flaunt their private lives as a means to preach and moralise at us. The royals are

particularly guilty of this. As *Mirror* editor Piers Morgan said in opposing a privacy law, the royals are 'happy to dance with the devil when it suits them' (*Guardian*, 9 June 1997). They were the ones who encouraged the media to present them as a 'perfect family', in a cynical strategy to perpetuate support for the monarchy. They can hardly complain now that their strategy has blown up in their faces. Politicians also use their personal life as a way to make themselves more popular—see the carefully staged family shots of the smiling Blair family arriving in Downing Street, going to church, holidaying in Italy etc. Public figures cannot have it both ways. If they make their private life a matter of public interest, they cannot then complain when people ask questions about it.

In the recent debate about privacy legislation, a number of 'ordinary people' have complained that they too have suffered unwelcome intrusion from the press. Sometimes people quite understandably complain that they are persecuted by a prying press that seeks to expose every sordid detail of their personal life. But even looking at these kind of cases there is still no convincing case for a privacy law. In framing any kind of privacy law the dangers of excluding a legitimate arena of discussion far outweigh the fact that individuals can suffer at the hands of a salacious press.

Take for example one particularly harrowing case that was discussed on a recent chat show devoted to the issue of privacy. A guest on the show complained that the press invaded his privacy after he assisted in the suicide of a close friend. Details of his actions and both his and the dead man's private lives were splashed across a national paper without his permission. Certainly we can all sympathise with his desire to get the prying press off his back. But does our sympathy at such a time mean that the entire incident should have been protected by a privacy law?

Assisting in a suicide is currently against the law in this country. Since the man chose to break the law is it not reasonable that society should want to examine the very personal reasons that led him to do so? Of course there is no reason why this meant that the press had to pry into irrelevant aspects of his sex life, but it is simply impossible to frame

# WHY ARE WE ALL SO DEFENSIVE ABOUT WHAT WE REPORT?

*Tessa Mayes on how a 'safety-first' attitude has already emasculated investigative journalism*

If **privacy legislation** is not imposed on the press, it will be because just about everybody in the media is bending over backwards to make concessions to the censors and promising tighter self-regulation. Whatever happened to the fearless spirit of investigative reporting?

Princess Diana's death prompted bitter infighting and recriminations among the different sections of the media. The tabloids blamed the paparazzi 'scum', the broadsheets blamed the tabloids for creating a 'thirst' for salacious pictures, television people accused press people of showing no respect, press people accused television people of hypocrisy. Everybody in the media is accused of being in some way to blame, and everybody accepts that the media must act more 'responsibly'.

The fact is, however, that investigate reporters

are already tied up in legal knots, and there is already a powerful safety-first mood among editors and reporters alike, who are increasingly unwilling to tackle controversial stories. With a 'free' press like this, you might ask, who needs privacy laws?

The BBC's own internal 'Producer guidelines' warns reporters that their work must not be 'intimidatory or unreasonably intrusive', and must not 'harass people unfairly with repeated telephone calls or repeated knocks at the door, or by obstructing them as they come and go'. Independent TV companies adhere to similar rules under the Independent Television Commission (ITC) code. The National Union of Journalists has rules on intrusion as does the Press Complaints Commission, whose code of conduct states that journalists should not obtain information or pictures through

intimidation or harassment. Such regulations always have to be read before asking your editor if you can use secret cameras, hidden microphones, telephoto lenses and TV cameras aimed at gathering information on individuals.

**Laws governing journalists** who wish to publish serious allegations against public figures include 'D' Notices, court injunctions, the 1985 Interceptions Act and the 1924 Telegraphy Act. You know you are on dangerous ground when the programme lawyer returns your call and reminds you of the finer points of the law on trespass. To 'publish and be damned' is a thing of the past. The current vogue is more like 'check with your lawyer, then check again, and perhaps publish a watered-down version after very careful consideration at senior editorial level'.

## Why should the royals, politicians and the courts be allowed to determine what is a LEGITIMATE ISSUE for public debate?



a law that allows us to look into certain aspects of his personal life and not others. Every case will be different. To have a law that draws an arbitrary line between, say, money matters and everything else is simply too rigid to allow full discussion on matters of public interest. The fact that the press acts in a tasteless and thoughtless fashion cannot be a reason for drawing strict boundaries around what we can and cannot discuss.

ANOTHER CASE HIGHLIGHTED BY JOHN WADHAM of Liberty raises difficult problems. He complained that one of Liberty's clients was caught on a CCTV camera trying to commit suicide in a public place. Rescued by somebody who spotted him, he then tried to put the incident behind him and get on with his life. A television station later obtained the film and screened the incident on the local news. This seems to be particularly cruel; but even in this case the argument that the man's privacy should have been respected in law is a difficult one to sustain. Certainly there are questions to be asked. How for instance did the TV station get hold of the film? But to say that there should be a law in place to prevent this type of intrusion goes too far.

Imagine that the film had been obtained by, say, a TV crew secretly filming rather than CCTV. Would it be wrong to film

an incident that anybody in the public space could have witnessed? How is society to legislate for what would be legitimate to film in public and what would not? Some say you should have to gain people's consent but this is not always a good criterion. In 1991 somebody with a camcorder famously recorded the LAPD beating up Rodney King in a public place. The police did not consent to the filming. Nobody however could seriously argue that this film should not have been shot or shown. It is very easy to imagine that, once society has rules about what personal behaviour could and could not be shown, then powerful sections of society like the LAPD would have another censorship law to hide behind. To rule that anything which takes place in public is out of bounds for the media sets some dangerous precedents.

Why should the royal family, politicians, the courts or even Alan Rusbridger be allowed to determine in advance what is and what is not a legitimate matter for public debate and discussion? All these characters have their own motives for limiting public discussion. In elevating the right to privacy, most of these people are telling us that they value their own privacy and privacy for their kind over and above free speech. That may be good for them but it will not serve the interests of society as a whole.

Rusbridger appears to have more noble motives but when it comes down to it, I think it is no accident that he too now sees the merits of a privacy law. Cynics might assume that he simply wants to protect his mates in government, but that is a misreading of his motives. *News of the World* editor, Phil Hall, was surely closer to the truth when he observed that 'Alan Rusbridger and the rest are imposing their own tastes in journalism on everyone else'. Rusbridger has his own agenda, one that is in its own way just as petty and scandal-mongering as the tabloids. For the *Guardian*, serious journalism and politics now seem to be reducible to the issue of sniffing out 'fat cats' and exposing financial sleaze. If that is what serious public debate is reduced to, then why should they care if the press is prevented from reporting anything else in which the rest of us just might be interested?

You can find your story is almost dictated by the lawyers. In consumer journalism, lawyers will tell you what kind of laws are being broken by the subject of your inquiry (which can give the story a harder edge if you know x is breaking y law), before getting to the punchline: the media laws which govern how you can go about reporting such activity. You heed their advice.

**Working on several** investigative programmes, I constantly had to chase the lawyer to find out what kind of evidence was sufficient, in legal terms, to air a story. Your editor expects this, your producer expects this, and the channel controller would look dimly on your journalistic credibility if you did not do it. It is called being a 'responsible' journalist.

However, it is infuriating to find, say, that certain allegations about influential people cannot be broadcast even if you have done the homework, because the media company does not wish to risk a costly legal case or you might have an overcautious editor. On one occasion I was told that my programme had enough 'angles' to be watchable and the extra allegation (although backed up by facts) was seen as offering little reward in terms of audience figures and high risk

in terms of the law. Such is the 'chilling effect' of all media laws.

Many journalists claim they want to broadcast a story but their hands are tied by the rules. It is a risky business as an investigative journalist to wonder whether a story is worth breaking if it means losing your job or ending up in court. Yet a safety-first mentality damages investigative work. Journalists end up self-censoring their own work. It means that more stories are being stopped before investigation begins.

Martyn Gregory, maker of the award-winning Channel 4 documentary *The Torture Trail* (which revealed the trade in electroshock batons by British companies) has witnessed the increasing timidity of the major TV channels as a result of new laws and regulations. 'Not all of the rules are aimed at investigative journalists', he explains, 'but most of the laws have been used against us'.

The words 'privacy laws' immediately invoke fears of censorship. However 'media harassment' is becoming a more acceptable reason to curb the media, especially among media people themselves. But what is to stop investigative journalists being stopped the moment somebody points the accusatory finger in the name of 'harassment'? The

result would be the same: a news blackout on more areas of life. Some people deserve harassing, particularly if they are public figures evading serious allegations.

**It is as if** journalism is imploding on itself. Before, you had external authorities—the law courts, regulatory bodies, MPs—to deal with. Now all kinds of journalists who you would think might be against such laws have voiced their support for further restrictions. Reporters are fighting among themselves to defend their brand of journalism at the expense of another.

I used to think that at least those working in the media were united in defending the freedom to write or broadcast what they wanted, in the spirit of enquiry and public knowledge. The decline in self-belief among journalists is now accelerating. At this rate, the Fourth Estate will soon become the Fawn Estate.

TESSA MAYES has worked as an investigative journalist for the BBC, ITV's *The Cook Report* and Carlton TV. She is currently researching the impact of a privacy law on journalism for The Freedom and Privacy Project commissioned by the London International Research Exchange media group.

*Mick Hume explains why LM magazine is refusing to give in to ITN's libel writs and gagging orders*

# A FIGHT FOR FREEDOM AND THE TRUTH

**A**s editor of *LM*, I am being sued for libel (along with the publisher Helene Guldberg) by a mega-corporation in a case which threatens to bankrupt our magazine. The multi-million pound company that is trying to silence the independent voice of *LM* is not McDonalds or Shell, but ITN—a media giant which is itself supposed to be committed to journalistic freedom.

The case centres on the article 'The Picture that Fooled the World' by German journalist Thomas Deichmann, published in our February 1997 issue, which raised embarrassing questions about ITN's award-winning pictures from a Bosnian Serb-run camp. (For a brief summary of Deichmann's case, see box below.)

ITN first demanded that we pulp every copy of the offending magazine, apologise and pay damages. When we

declined to do so, they issued writs for libel—the legal gagging orders which the rich can hire in a bid to silence their critics. The magazine is now embroiled in a long and costly legal battle. ITN and its lawyers have made it clear that they are not simply seeking to set the record straight, but to inflict punitive damages on *LM*—in effect, to put us out of business and gag us for good.

So why is our small magazine, with its shoestring resources, prepared to risk ruin by standing up to ITN? Because there are important principles involved which symbolise what *LM* is all about, and on which we are not prepared to compromise.

*LM* stands for freedom of speech and a free press. We insist upon our right to report the truth as we understand it without fear of offending public opinion or upsetting powerful interests. It is not for ITN, the government, the

courts or anybody else to dictate what facts and arguments we can and cannot make available to our readers.

There is now a more pressing need than ever to make a stand for the right to free speech. A repressive code of moral correctness dominates much of public discussion today, dictating that those views deemed 'extreme' or 'offensive' by the self-appointed guardians of the nation's ethics should not be heard at all. Such a not-in-front-of-the-children attitude to public discussion should be an anathema to anybody interested in freedom and democratic debate.

(For an exposé of how this trend is distorting war reporting, read the *LM* special 'Whose war is it anyway? The dangers of the journalism of attachment', a pamphlet which came out of the issues raised around the libel case. See p14 for details.)

## THE PICTURE THAT

This is a brief summary of Thomas Deichmann's revelations about the award-winning ITN pictures from Trnopolje camp. For the full story, see 'The picture that fooled the world' in the February issue of *LM*.

On 5 August 1992, a British news team led by Penny Marshall (ITN for *News at Ten*), with her cameraman Jeremy Irvin, and fellow reporters Ian Williams (ITN for *Channel 4 News*), and Ed Vulliamy (the *Guardian* newspaper) visited Trnopolje camp in the Bosnian Serb territory of northern Bosnia. They left with striking pictures



of the emaciated Fikret Alic and other Bosnian Muslims apparently caged behind a barbed wire fence.

These pictures were broadcast around the world, and immediately became the defining image of the horrors of the war in Bosnia. In particular, the world media held up the picture of Fikret Alic behind the barbed wire as proof that the Bosnian Serbs were running a Nazi-style 'concentration camp', or even 'death camp', at Trnopolje. The impact of these images was to colour all subsequent coverage of the war, and to prove

The other central issue at stake in the case is the rewriting of history. For five years, the misleading ITN pictures of emaciated Bosnian Muslims apparently encircled by a barbed wire fence at Trnopolje camp have been used around the world as the proof that the Bosnian Serbs ran Nazi-style 'concentration camps', or 'death camps' as Pulitzer prize winner Roy Gutman called them.

The implicit parallels drawn between the Bosnian conflict and the Holocaust are doubly dangerous. They distort the truth about Bosnia by demonising one side in the civil war. And more importantly still, they belittle the true horror of the Nazi Holocaust against the Jews by comparing it to what was a bloody but unexceptional local conflict.

*LM* has been accused of 'historical revisionism' for daring to question the demonisation of the Serbs as Nazis. It is surely not 'revisionism' for *LM* to insist that there is a difference between a refugee and transit camp like Trnopolje, however grim, and a real concentration camp like Auschwitz, where the Nazis killed perhaps 100 times as many people as died in the entire Bosnian war. Those who imply otherwise really do run the risk of rewriting history, by trivialising the genocide against the Jews.

As the veteran Nazi-hunter Simon Wiesenthal said when the camps in Bosnia made world news in August 1992, 'To call the camps "concentration camps" is a minimisation of Nazi concentration camps, because not even the gulag camps could be compared with the Nazi camps'.

It has always been a central concern of *LM* magazine to expose attempts to rewrite history which relativise the Holocaust, and so by implication belittle the great crime committed by capitalism in the twentieth century. That is one reason why we have consistently challenged the casual Holocaust-mongering practised by those liberals in the West who called Saddam Hussein 'the new Hitler', who claimed that the Rwandan civil war was 'the century's third genocide', and who suggested that the Bosnian Serbs were running 'concentration camps'.

Unfortunately, today it seems impossible to question the liberal consensus on these issues without being branded pro-Serb or accused of revisionism and 'Holocaust denial'. It is to be hoped that, as we continue to fight our battle with ITN in the

public arena, more people can see beyond the hysterical name-calling and make a critical assessment of the facts.

Nobody should have the right to buy immunity from criticism through the courts, or to rewrite history without facing public cross-examination. If we are to carry on our fight around these issues in the face of overwhelming odds, *LM* needs all of the help we can get. We need moral, political and above all, financial, support.

Already our resistance to ITN's libel writs has won some important support at home and abroad (for example, see the appeal on p42). If you want to help take a stand in defence of freedom and the truth, you can get in touch with the *LM* libel appeal, The Off the Fence Fund—see the advert on the back page for details.

Nobody should have the  
right to buy  
**IMMUNITY FROM**  
**CRITICISM**  
through the courts

# FOOLED THE WORLD

instrumental in persuading the American and British governments to adopt a more interventionist policy towards Bosnia.

But the image of Trnopolje as what British newspapers called 'Belsen '92' was misleading. Fikret Alic and the other Bosnian Muslims in the picture were not encircled by a barbed wire fence. There was no barbed wire fence surrounding Trnopolje camp. The barbed wire was only around a small compound next to the camp, and had been erected before the war to protect agricultural produce and

machinery from thieves. Penny Marshall and her team got their famous pictures by filming the camp and the Bosnian Muslims from inside this compound, taking pictures through the compound fence of people who were actually standing outside the area fenced-in with barbed wire.

Whatever the British news team's intentions may have been, their pictures were falsely interpreted around the world as the first hard evidence of concentration camps and a 'Holocaust' in Bosnia. They became the pictures that fooled the world, the most potent

symbol used to support a misleading interpretation not only of Trnopolje camp, but of the entire Yugoslav civil war.

Penny Marshall and Ian Williams did not call Trnopolje a concentration camp; nor did Ed Vulliamy at first, although the more time elapses, the more certain he seems to be that there was one after all. All three British journalists have expressed concern at the way in which others used their reports and pictures as 'proof' of a Nazi-style Holocaust.

Yet none of them has ever corrected the false interpretation

placed upon those pictures, by telling the world the full story of that barbed wire fence and explaining how the famous Trnopolje pictures were actually taken. Why? Thomas Deichmann's question has been met by with libel writs, gagging orders, threats and slanderous insults, but no answers.

If you would like to read Thomas Deichmann's investigation in full you can buy a copy of February's issue of *LM* (No97) by sending a cheque for £3 to BM JP Graphics, London WC1N 3XX made payable to JP Graphics.

*A college photography tutor has been forced to resign for treating mature students like adults. Jennie Bristow reports from Teeside*

## NORTHERN EXPOSURE

In May Denis Dunning, a photography lecturer at Stockton and Billingham College of Further Education, suddenly disappeared. His students on the Wednesday night City and Guilds 747 course in Professional Photography wondered where he was. 'First we were told that he had suffered a bereavement, then we were told that he was ill', said Steve Williams, aged 44.

It soon became clear that something else was going on. College staff raided the photography studio, breaking open cupboards and seizing students' work. Students Julie Clayton (24), Steve Jackson (46) and Pip Oram (38) were called in and interviewed by college management. On 22 May Andrew Smith, a 35-year-old student on the course, was sent a questionnaire by John Kirk, executive director of Human Resources at the college. It began 'I am conducting an inquiry into possible serious misconduct by staff and/or students at the college', then asked Andrew Smith whether he was acquainted with Julie, Pip or Steve, and whether he used his home darkroom for processing nude or semi-nude photographs. By the end of June, Denis Dunning had resigned from his post, having signed an agreement that he would talk to nobody about the case, and the students were informed that the CG747 class was cancelled. The story of alleged seedy goings-on in the photo studio quickly made it into the national media.

Serious stuff; yet the students and Dunning are accused, it seems, of no more than taking some nude or semi-nude pictures of each other which, for an art class, does not seem like such a big deal. It is an evening class aimed at mature students, all bar one of which is over 23. Since Denis Dunning has worked at the college for over 20 years, you might presume him to be a valued member of staff. So why did the college react in such a heavy-handed way, with raids, inquisitions and forced resignations?

The college's reaction reflects the new rules and fears governing the management of further education today. Denis Dunning unconsciously transgressed the professional boundaries now placed between

students and tutors; and the college, in its desperation to avoid a scandal, cracked down. But in reacting so strongly, the college has brought to light the ambiguities and contradictions inherent in managing relationships between tutors and students in education today.

The main controversy has centred on some photographs taken of Julie Clayton, mimicking poses made famous by Christine Keeler, the call-girl at the centre of the 1960s Profumo scandal. Some of these appear to be nude pictures, although Colin Harper (47), who took them, claims that Julie was wearing a swimsuit. Harper is outraged by the notion that these photographs are pornographic. 'None of my work is pornography: there are no shots of naked men or women in my portfolio.' In any case, argues Pip Oram, why would it have mattered if the photographs had been nude? 'At the time when all of this was going on, I was asked by one of the art teachers to pose nude in the art class. What I can't work out is—it's legal to go to one of the art classes and sit baring everything and get paid for it, but I can't do it for 125th of a second in the photo studio behind screens.'

Pip Oram has a point. Life drawing forms an acceptable part of most art classes, and given the lack of formal rules at Stockton and Billingham College governing the taking of photographs, it is difficult to see why students taking pictures of other students in swimming costumes should have caused such outrage.

Oram also showed me some more photographs used in the inquiry into Denis Dunning. Taken a year ago for Dunning's own MA course studies, they show a naked Pip in various poses. Pip Oram says he offered to pose for Denis as a mate, and argues that there is nothing wrong with his posing for the pictures, or Dunning taking them. To the college, however, they were clearly suggestive of an 'improper', intimate relationship between the tutor and his student.

More than ever before, further and higher education institutions are concerned to prevent any 'non-professional relationships' between staff and students. At its 1995

conference, the university and college lecturers' union NATFHE passed a motion stating that such relationships were 'ill-advised, unprofessional and to be discouraged'. NATFHE's advice booklet on the subject, published in 1996, makes clear that formal rules do not have to be broken for college management to discipline its staff: college managers 'are prepared to treat as disciplinary offences a whole range of behaviour towards students which is not explicitly forbidden'. This obviously includes sexual relationships. Just what else is included in the 'range of behaviour which is not explicitly forbidden' depends, it seems, on the mindset of college management.

When Steve Jackson was interviewed by Stockton college management, the questions soon moved on from the Julie pictures to Dunning's relationships with the students. 'We used to go on field trips to the Lakes, and they started interrogating me about that', he says. 'At one point they showed me a picture of Den with his arm around Julie, and asked me, what is the nature of their relationship? They started talking about Julie writing to Den and feeding him out of yoghurt pots. They showed me a tube of chocolate spread found in a cupboard in the studio, and said that there were photos of Julie with chocolate over her body.'

According to Steve Jackson, there are innocent explanations for all of this in a class where students and tutor are mates and have a laugh together. And even if all of the accusations were true, you might say, so what? If a 24-year-old woman wants to have an intimate relationship with her tutor, get her tits out for the lads or even be photographed wearing nothing but chocolate spread, that is surely up to her. But such broadmindedness is banned in further education today.

Normal, adult behaviour, when viewed through the prism of harassment codes and the paranoia of college management about 'unprofessional relationships', can become distorted and the worst can be assumed. When the rules state that everybody should be treated like children, adult behaviour is simply not on, and 'mature' students have to be treated like vulnerable children.

Julie Clayton (24)  
was photographed  
by fellow student  
Colin Harper

## Why would it matter if the **PHOTOGRAPHS** had been nude?

From nude shots to digestive biscuits to bad language, everything that went on in the CG747 class is indicative of an environment that is less like a schoolroom than a gathering of mates. The students would come together and get on with their work because they liked being there and doing photography: not because they had to be there, or wanted qualifications.

One student objected to the way he was now being fast-tracked through his certificate by a college keen to get the passes it needs to protect its funding: 'When I started, they told me there was no time limit on the course. Now certain people are saying that Denis was not getting people through exams fast enough.'

The joking, camaraderie and intimacy among the students continued even when the college added a 15-year-old girl, Rachel Hingley, to

notified her parents or social services. But it was not the presence of a minor in the class that caused the problems.

The rules governing sexual relationships between students and tutors exist regardless of the students' age: the argument is that tutors are in a position of power over their students, so the relationship is necessarily unequal and even coercive. Indeed, any behaviour that would be deemed unacceptable towards minors is now frowned upon even if the students are adults. Imagine the outrage if a teacher allowed his class of under-16s to take sexy pictures of each other. If adults and children are now said to occupy the same position in relation to their tutor, it is little wonder that the college turned on Dunning.

Twenty odd years ago, when Denis Dunning started at Stockton and Billingham, further education was a different world and the complex of rules and codes governing 'appropriate behaviour' did not exist. Why would he think there was anything wrong with allowing his enthusiastic class of mature students a free reign with their ideas? And why would the twenty-thirty-forty something students in his photography class, to whom a bit of tit and bum is as commonplace as fish and chips, see anything even slightly perverted in pictures of a 24 year old in a swimming costume?

Andrew Smith, a builder by trade, says the affair has 'left me with a bitter taste in my mouth'. The others nod in agreement. That bitter taste comes from losing their course and their tutor amid rumours that they are

perverts and weirdos ('We're called the nudie club at college, and it is horrible', says one). These students are not perverts or weirdos, and

I do not believe their tutor was either. They are adults on the sharp end of a college which treats everybody like kids, and seems to care more about its reputation than the students' enjoyment of the course they have paid for and invested their time in.

So much for 'adult education'. Maybe 'Stockton and Billingham Nursery' would make a better letterhead.

the class.

'We treated her like one of the lads', said another student.

Rachel Hingley and her parents have supported Dunning, and as Rachel says, if the college really thought there was a problem they should have



# THE DUMB OF HIGHER

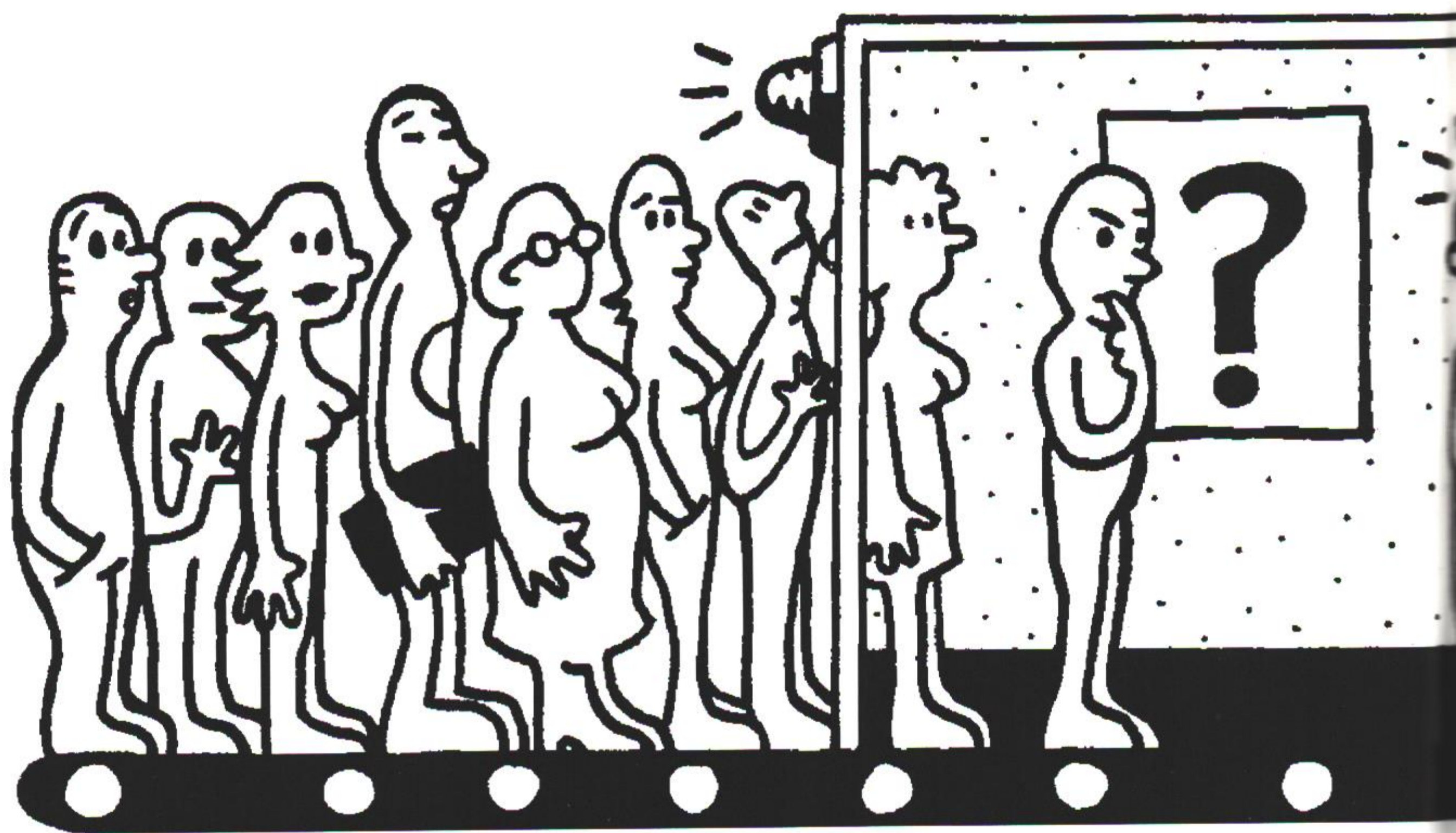

*If New Labour is allowed to get away with implementing the Dearing Report, says Claire Fox, it is likely to mean the end of university life as we know it*

**S**ir Ron Dearing's report *Higher Education in a Learning Society* was the educational story of the summer (along with the scapegoating of the Teletubbies for a decline in the nation's literacy standards). The educational world waited 14 months for Dearing's 16-strong committee to complete its 10 volume report. But for such an eagerly awaited document, the surprise was how little serious attention was given to the substance of the final Dearing proposals. When Education Secretary David Blunkett quickly endorsed Dearing's controversial proposal to make students pay for higher education, the issue of tuition fees became almost the sole focus of academic and media discussion.

Yet tuition fees are one of the least interesting and least dangerous aspects of the proposals for university education. After all, in effect students have been paying for higher education for some time. With degrees offering fewer career

opportunities these days, people are queuing up to pay for post-graduate courses, while undergraduates are already attuned to accumulating debts of thousands of pounds; in this context the prospect of tuition fees hardly seems to merit the furore.

Worse, the bluster about fees diverted attention from a far bigger problem with Dearing's proposals. The report endorses a new philosophy about what higher education is for and what students can expect from university. It heralds a further shift away from ideas of scholarship, free thought, and high-level cultural and scientific education and research, towards notions of utility, measurable economic worth, and training. The Dearing Committee, and New Labour's promised implementation of reforms in HE, are likely to be responsible for the greatest dumbing down in Britain's university history. Dearing makes the Teletubbies look positively academic.



# BRINGING DOWN EDUCATION

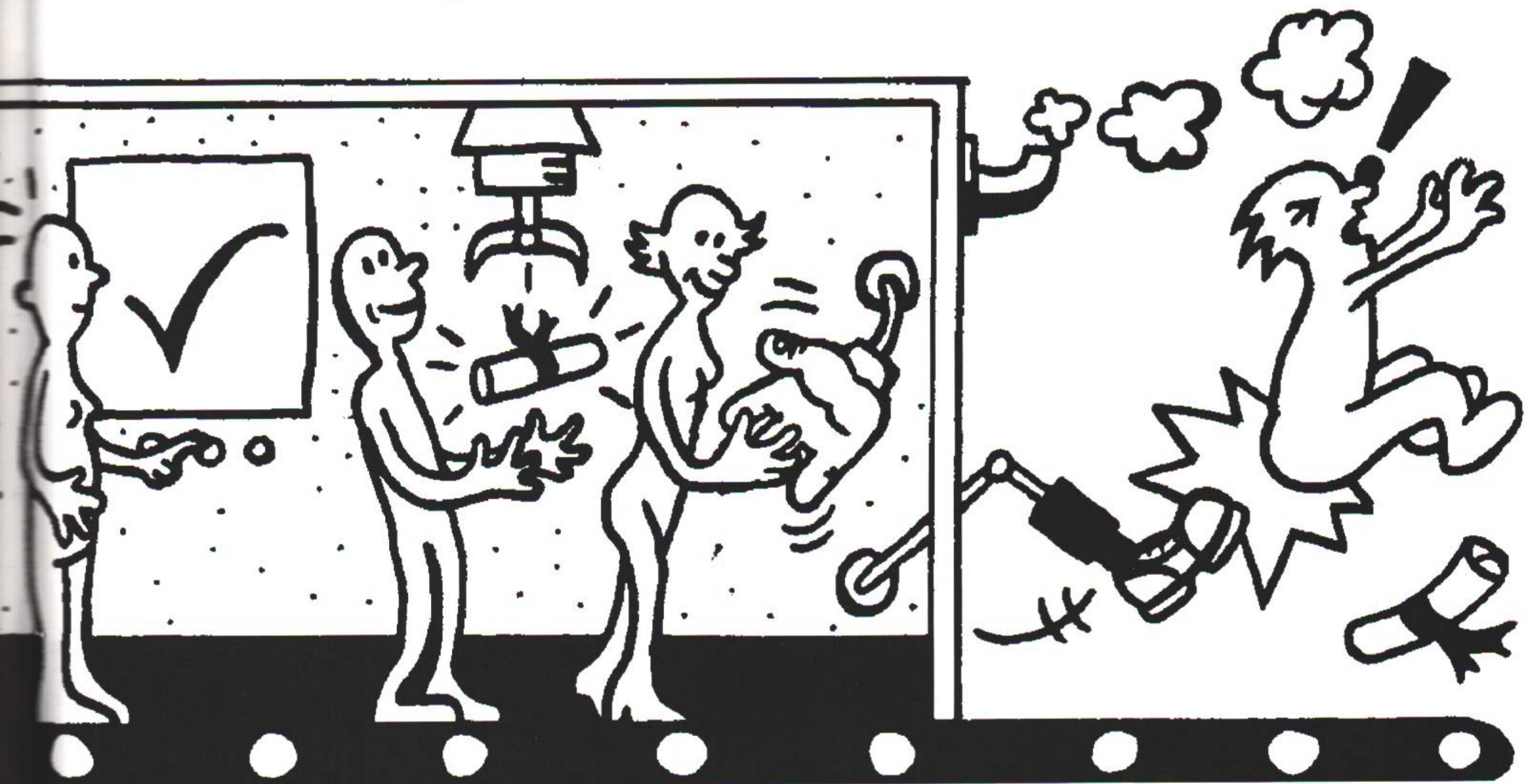

The new low quality higher education has been introduced with little comment. Indeed the common perception of the *Dearing Report* is that it will actually halt the decline in quality HE provision. On paper at least Dearing arrives on his white charger to save standards with brave proclamations of defending knowledge for knowledge's sake. But the details of the report contradict this.

Take for example the proposal to set up an Institute for Learning and Teaching in HE, to improve teaching methods and to take responsibility for new teacher training qualifications for lecturers (Recommendations 13,14,48). It sounds like a good idea that can only improve the quality of higher education. On closer inspection, however, it becomes clear that this proposal has seriously detrimental implications for the whole nature of university life and standards in HE.

On what does Dearing base his assertion that lecturers are not teaching properly? One of the key groups consulted on the question of lecturers' teaching abilities were students. Their perceptions have been used to argue that the more research-orientated a university is, the less students are satisfied with the teaching they receive. Earlier this year Frank Webster, a sociology professor from Oxford Brookes

University, wrote in the *Times Higher Education Supplement* that, 'while many university teachers here in Britain identify with and aspire to combining research and teaching, there is little evidence that undergraduate students benefit from or are even aware of the research conducted by their teachers' (3 January 1997).

The *Dearing Report* cites a Policy Studies Institute survey of 1200 students, where almost a half of those who responded were less than satisfied. In its contribution to Dearing, the National Union of Students complained of a slowness in introducing new teaching methods and bemoaned the fact that current funding mechanisms reward good research much more than good teaching. After publication of the report, NUS President Douglas Trainer boasted that 'The student voice was heard, and we remain the most considered party within the report's findings' (*THES*, 25 July 1997). The report itself claims that it 'puts students at the centre of the process of learning and teaching' (see Recommendation 8).

Taking on board the views of students sounds very empowering. Students may well feel they have long been the victims of bumbling academics with few social skills, let alone teaching skills. Wouldn't quality improve if that boring old ►

◀ lecturer was taught how to communicate his ideas to students instead of droning on and sending everybody to sleep? Surely Dearing is right to take note of student complaints about the professors who don't turn up for lectures because they are too busy on their latest research experiment.

But what does it say about education when the people asked to rate the quality of HE are the students—the least educated constituency in the university and the least likely to be able to judge what they should be getting from lecturers? The stock images of other-worldly nutty professors, swotty academics and nerdy researchers are usually associated with a philistine response to academia. Now it seems they are to inform public policy. The implications for the quality of HE are potentially dire.

Dearing follows the contemporary fad for student satisfaction surveys which at best produce banal complaints of the 'not enough handouts...too few seminars' variety, that confuse quantity with quality: worse, Dearing elevates the complaints of undergraduates who perhaps understandably complain of rigour and testing as problematic. What student spontaneously welcomes the pain and effort of being intellectually stretched? But the moans of students who might prefer study to be easy and to fit in with their social life should surely not be taken too seriously. When the NUS submission to Dearing complains about 'the continued dependence on lectures and exams' you suspect the preference is for some **childish regime of group work**, less homework and class quizzes. Dearing stamps these lowest common denominator responses with the seal of approval.

**Dearing's student-centred approach** reflects the new ethos of a university sector which has attempted to ape the market relations of the rest of society. Keeping the consumer happy has led to all manner of services being reorganised around customers, and education is no exception. This market rhetoric has been part of HE for some time and many feel it is one of the culprits responsible for falling standards. Lecturers are warned that students will take their 'custom' to other educational institutions if they are not satisfied with the marks they receive, while more students who feel they have not got what they were promised in the college's adverts threaten to sue, as if they had bought a dodgy TV. The result has been the introduction of easier assessment methods, and the inflation of the number and class of degrees issued, in a marketing effort to keep student customers happy.

The message of the *Dearing Report* makes clear that the market-orientation of education is not some Thatcherite hang-over. It is now to be cemented in the more politically correct language of student empowerment as befitting the New Labour regime. The entire emphasis on improving university teaching is now framed in the context of the decision that students should pay their own fees. Now the customer/provider relationship is more sharply posed; students are to pay hard cash and, as Dearing says, they will expect to get the product they ordered. This will alter all relationships in universities. Power and authority will no longer be derided from knowledge, specialism, expertise in the field. Instead the academic/student relationship will be equalised through a contract, with an emphasis on what students get as consumers. This will increase the tendency to view degrees as ready-made, saleable commodities. Satisfied customers in University Britain plc demand a worthwhile product.

But how do you measure the 'value' of the new product on sale at supermarket universities? The *Dearing Report* spells out that students should expect 'a reliable education which is respected in the marketplace' and flags up a new role for universities to produce more 'work-ready graduates'. This is, in accountancy-speak, the bottom line. University education under New Labour is now formally recognised as an elaborate job training scheme. No wonder lecturers will need to attend the Institute of Teaching and Learning. Their role is to change from that of members of the academy to purveyors of

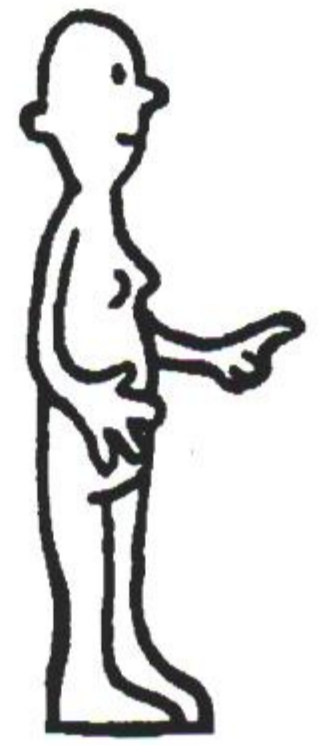

employer friendly CVs. In the name of keeping students satisfied, university life is being narrowed down to a set of vocational outcomes. The aim is not higher education, but more 'employability'.

The trend towards vocationalism, evident over the last few years, is now to be given even more prominence. Dearing suggests year-long work experience placements even on non-vocational courses such as classics (Recommendation 19). He has noted employers' criticism that academics should spend less time researching and writing books, and more time teaching their students the core skills 'fundamental to the modern age'. The likes of Tesco's chairman Sir Ian MacLaurin say present-day graduates are 'pretty well a dead loss for the first few years' because they have not 'learnt to communicate properly', they cannot 'write a report or stand up and make a presentation' (*Independent*, 7 November 1996). Don't worry Sir Ian, Sir Ron is here to save the day. He suggests that these key skills are to be written into degrees, giving students a grounding in technology, communication skills and numeracy, a sort of high-level 3Rs for undergraduates (Recommendation 21). When university education is reduced to a course in office skills, it should be clear that students will be the biggest losers in the rise of 'student-centred', vocational education.

University education was supposed to be about gaining knowledge, assimilating facts, considering ideas and concepts, training the mind in critical thinking. All of these aims are now secondary at best, as the determination to ensure students end up with a saleable paper qualification and the practical skills most appreciated by employers overrides all else. Being educated takes a back seat—at least in any sense of an open-minded, humanist university education that, as one Dean of America's Dartmouth College put it, 'encourages bright people to imagine the unimaginable, think the unthinkable and deal with the unpredictable'. When universities instead take Dearing's functionalist view of education as 'a powerful weapon for economic development', with a recommendation that all courses of study 'help students to become familiar with work, and help them to reflect on such experiences' (Recommendation 18) the only thing contemporary students will be encouraged to imagine will be the kind of unsatisfying work that awaits them at the end of their study.

The concern to break down the boundaries between the world of the university and the world of work expresses a big change in what higher education means to society. It is worth considering why universities were set apart from the rest of society. One commentator summed up the idealised vision of higher education in 1945, on the eve of the post war expansion of the university sector: 'The primary aim of the university must be [to] search for knowledge—research as we call it today: not merely actual discovery, not merely even the attempt to discover, but the creation and cultivation of the spirit of discovery. Imagine a group of men, in any age, retiring from the life of the world, forming a society for the

# DOWNGRADING research in favour of teaching reduces university education to MERE TECHNIQUE



pursuit of truth, laying down and voluntarily embracing such discipline as is necessary to that purpose and making provision that whatever they find shall be handed on to others after their deaths. They pool their material resources; build a house; collect books; and plan their corporate studies. This, in its simplest form, is the true idea of the university.' (B Truscott, *Redbrick University*, 1945, p69) Whatever you think of the elitist tone of this vision, it at least expressed an ideal that the pursuit of knowledge should be separated from the pressures of the marketplace, and free from the demands of government, sentiments captured in the notions of academic freedom and a community apart. The Vice Chancellor of Sussex University, Professor Gordon Conway points out the significance of such an ideal: 'At the heart of a modern society there must lie [the] freedom to engage in research irrespective of the direction it may take. It provides the basis for a questioning society which is unconstrained by fads and fashions.' (*Observer*, 23 March 1997)



**Dearing's move** to break the link between university teaching and research represents an assault on the very idea of higher education. The belief that research and teaching must be closely linked reflected a view of universities as special places of scholarship and knowledge, where academics were at the cutting edge of social progress, expanding ideas and researching new areas. Undergraduates were educated by interacting with this atmosphere and with the people who were pushing society's intellectual boundaries outwards. The education process lay less in the technical teaching of subjects,

and more in allowing the new recruits to academia access to the greatest minds in the field. This was not school, but an apprenticeship to becoming independent thinkers. The essence of university education is dependent on giving precedence to research. The relationship of research to good teaching is the understanding that what inspires young people is the stimulation and challenge of dealing with new and, yes, difficult ideas, the intellectual excitement that emerges from an atmosphere of originality and scholarship. If they are to be university teachers in any meaningful sense, lecturers need to have the opportunity to pursue an active and creative research relationship with their subject.

In downgrading research in favour of simple teaching, Dearing's proposals reduce university education to a technique. One commentator on Dearing, the OU's David Bourne, makes this clear: 'If we come up with a clear account of what it means to be a competent teacher, we can encompass a huge variety of teaching types.' This sense of a list of tasks that add up to a competent teacher ignores the importance of what is taught, instead concentrating on how it is taught. Indeed, nowhere in the *Dearing Report* does the issue of educational content and good teaching emerge as a couplet. This mirrors what has happened in the further education sector. Here, staff development—which used to mean secondments and courses in developing subject specific knowledge—has been replaced by workshops on class management, interpersonal relationships and the use of IT.

The new institute for HE teachers is likely to employ the tick box competencies of NVQ world—so disastrous to education in schools and FE colleges—to assess the quality of university lecturers. Breaking the job of teaching down into assessable units is particularly dangerous when applied to universities, and will lead to the equation of banal practical tasks with ideas ('Good use of the white board'—tick; 'chairs arranged in a student centred appropriate manner'—tick; 'knows about biochemistry'—tick). This approach is already infecting HE. A job evaluation scheme involving 112 HE employers and the main HE unions called the Universities Competencies Consortium aims to make all the jobs in HE comparable in terms of standard competencies, weighting the role of admin staff, lecturers, cleaners and so on. Of course, once university teaching is reduced to a series of tasks, comparable to any other function, teaching becomes almost a rote activity. All hail the Institute of Teaching and Learning. Anybody can do it! Bring on the newly literate Teletubbies.

The new technique of training competent higher education teachers will be the most likely source of the further neutering of university life. Now that allegedly boring professor—who at least droned on about something worth hearing—will be replaced by a new version with flip charts and overhead projectors. This slick new corporate salesman may keep his customers awake with his communication skills, but the lecture will likely be contentless, informed by outdated, pre-Dearing research and post-Dearing prejudices. Stylish sound-bite professors, all form and no content, may look and sound as smooth as Peter Mandelson and Tony Blair, but will have little of value to communicate to students who may aspire to developing their minds.

Dearing waves goodbye to the idea that academics should bring their first-hand research and professional experience to the development of curriculum and its delivery. But then, if all that we expect from university is the preparation of our customers for the world of work, then a training course at the Institute in Communicating the Banal will suffice. Of course, satisfaction will be guaranteed—if all students demand from HE is a degree certificate and a grounding in work skills. Academics and students who want something a little more satisfying will need to send the New Labour/Dearing supermarket approach to education back to the manufacturers.

Who benefits from the new policy of lowering university standards in order to get more working class and disadvantaged students into higher education, asks Brendan O'Neill

## SECOND CLASS STUDENTS

As far as I'm concerned one of the biggest problems facing higher education is the major under-supply of working class students. The *Dearing Report* estimates that as few as seven per cent of young people from disadvantaged backgrounds make it to university, compared to 80 per cent of young people from more advantaged homes. This is a serious imbalance which needs to be addressed.'

David Robertson, Professor of Public Policy and Education at Liverpool John Moores University, has spent the past year advising Sir Ron Dearing on how to make higher education more accessible to working class students. Robertson's report, 'Widening participation in higher education by students from lower socio-economic groups and students with disabilities', was published in July as part of Dearing's national inquiry into the state of higher education. The *Dearing Report*, endorsed by the New Labour government, aims to increase the proportion of young people attending university from 32 per cent to 45 per cent over the next 20 years, and promises to prioritise funding for those institutions 'with the best record of attracting students from the working class, people with disabilities and disadvantaged ethnic minorities' (*Guardian*, 24 July 1997).

'What is most significant', says Professor Robertson, 'is that working class kids are under-represented irrespective of their qualifications. Even when poorer students possess the same standard of entry qualifications as their middle-class counterparts they are still only 70 per cent inclined to go on to university'. Robertson, who is currently a visiting research fellow at the Centre for Education at the London School of Economics, does not subscribe to the view that working class students are put off going to university by the threat of student debt: 'I don't have this kind of knee-jerk response that working class kids are more likely to object to debt than other groups of students. There is evidence that financial worries cut across all classes.'

So what accounts for the lack of working class students? 'I think the barriers are largely cultural', says Robertson. 'Universities are not looked upon as the kind of places that the working classes have traditionally gone to. Britain's universities are a product of a class society which has been about developing, sponsoring and maintaining a selective elite, and that can be very unwelcoming for poorer students. If we are going to make higher education inclusive and accessible, then universities need to change fundamentally: we need nothing short of an overhaul.'

Rather than improving pre-university education for working class students and pushing young people to raise their sights and fulfil their potential, Dearing and his supporters emphasise the need to alter universities to accommodate working class students. So what is it that today's educationalists want to change about university life?

'The most important thing is that we shift the emphasis from exclusion to inclusion', says Professor Roderick Floud, Provost of London Guildhall University. 'At many universities selection procedures are still about how best to exclude people. I think we need to start opening higher education

up to everyone who can demonstrate an ability to benefit from it. You may end up in a situation where you are taking people who will go on to fail, but it is better to take people and give them a chance than constantly seek to exclude them.'

During his thirty-year career Professor Floud has undergone something of a road-to-Damascus-style conversion on the issue of selection in higher education. In the late 1960s and early 1970s Floud lectured in Economic History at the prestigious University College London and at Cambridge. It was only when he became Professor of Modern History at Birkbeck College, University of London, in 1975, and began to teach many part-time and mature students, that Floud questioned the selection methods employed at Britain's more traditional universities.

'I started to find the selection methods being used at some universities deeply unsatisfactory. Take, for example, the scholarship examination at Cambridge: this is basically an exam to exclude people. Obviously there are a vast amount of students who would like to study at Cambridge, but most of them can't because there are only a certain number of places, so you have to start thinking of ways to exclude a great number of applicants. Exams like the scholarship one at Cambridge are also extremely susceptible to coaching: one was always conscious that one was dealing with students who had been very well coached to pass those particular type of examinations. And, of course, they were always the students from the more affluent backgrounds. Students from social classes four and five have very little experience of that kind of test.'

The clear implication of Professor Floud's criticism is that universities like Cambridge need to become less demanding, and maybe even to 'dumb down', to make themselves more welcoming to students from 'lower socio-economic groups'. But isn't this just the old argument that working class people are too stupid for university, dressed up in the egalitarian language of 'widening participation'?

'No', insists Floud. 'My fundamental objection to some of the older methods of selection is that you end up selecting people like yourself, people that you yourself would like to teach, and that is not the best method of selection. You end up excluding a particular type of student. We need to make higher education more inclusive of all students who want to fulfil their potential.'

What Professors Robertson and Floud seem to be arguing is that many of Britain's universities are too rigorous and elitist for working class students, who are often ill-prepared for a stuffy academic life. But it is surely only through examination, selection and exclusion that universities like Oxford and Cambridge have been able to maintain their high educational standards. Opening universities up to everybody who can 'demonstrate an ability to benefit' must compromise the academic excellence of these institutions. And how will devaluing higher education in this way help the students?

'What has happened in the recent past is that higher education has been expanded with no regard to the purposes of that expansion', says Professor Alan Smithers, Director of ►

Mod Langs & Optio Plymouth

Model Making & Vi  
Modelmaking Boun  
Rycotewood Coll\*; S  
Modern & Medieva  
Modern English St  
Modern Euro Studi  
Modern Euro Studi  
Modern Foreign La  
(French/(German)  
Modern Foreign La  
Kings Coll London  
Modern Greek Stud  
Modern Greek w A  
London  
Modern Hist & opti  
Modern Hist w Spa  
Modern Hist Dundee  
Modern Historical

Modern Historical Studies Lampeter

uton  
inguistics Essex  
dies Leicester  
by; w QTS St Martin Uni Coll  
ptions Salford; Lincs & Humbs;  
g; South Bank; Plymouth  
Econ Aberystwyth  
ntral Lancs; Huddersfield;

es w QTS Brighton  
astern Hist Manchester  
Scheme Wolverhampton  
Derby  
Stirling  
lar Bio Kent  
ptions Dundee  
erdeen; Herts; Leicester;  
ading; Queen Mary & Westfield  
Liverpool JMU; Dundee; Kings

Royal Holloway  
s Dundee  
io Aberdeen

Molecular Sci & Tech Leeds  
Molecular Sci Sussex

F  
is  
I  
E  
t  
di  
-t  
re  
re  
ut  
ut  
ut  
tr  
ol  
ic  
s

Queen Mary & Westfield Coll  
St  
St  
rb  
est  
me  
no  
m  
Ab  
m;  
r  
Dundee; E London  
Goldsmiths Coll; K  
London; Kingston  
Manchester; N Lo  
Nottingham Trent  
Westfield Coll; Re  
Hallam; Sunderland  
Maths (App) Man

St  
St  
rb  
est  
me  
no  
m  
Ab  
m;  
r  
Dundee; E London  
Goldsmiths Coll; K  
London; Kingston  
Manchester; N Lo  
Nottingham Trent  
Westfield Coll; Re  
Hallam; Sunderland  
Maths (App) Man

The important thing for  
**WORKING CLASS STUDENTS**  
 like Patrick is that they are  
**TESTED ON EQUAL TERMS**  
 with every other student in the country

◀ the Centre for Education and Employment at Brunel University. 'I think the previous government was troubled by the prospect of large numbers of unemployed young people and wanted to create something that they would volunteer to do; so HE has been expanded at a minimum cost. This has created a floodplain of students, waiting for the economy to pick up. The expansion has been rather directionless.'

Smithers, the author of *All Our Futures: Britain's Education Revolution*, is concerned about the quality of higher education today: 'Within the very small education system of 30 years ago there were fewer going on to university but they were starting from a high jumping-off point, so universities could run three-year courses and get people up to a very high standard indeed. Now we are starting from a lower base, and there is a question of whether we can get people to the same standard in three years. Some courses are already being lengthened to four years, and it is becoming more difficult to find the chemists and physicists and thinkers of the future.'

Smithers thinks that everybody should have 'the opportunity to develop their talents', but argues that we also need ways of spotting 'the people who are going to be the researchers and innovators of the future': 'If you think about it in terms of sport and health: everyone should have the opportunity to go swimming as part of becoming healthy. But there are only a few people who will be able to represent the country in the Olympic Games of the future.'

Sticking with the sport analogy, Smithers argues that selection is 'important and inevitable': 'If we are going to develop the intellectual equivalents of the Sally Gunnells and the Linford Christies, then we have got to find the people with the right aptitude and be able to develop those talents. As people go up the education system, differences in ability will emerge, they will have different interests and different aspirations: we need to be able to spot those differences and apply opportunities accordingly.'

Some commentators on education are prepared to go even further than Professor Smithers and suggest that increasing student numbers necessarily leads to a decline in standards. Eric Forth, Conservative MP for Bromley and Chislehurst, was a minister of state for education and employment in the last government. He has caused much controversy by suggesting that degrees are being devalued in the name of inclusion and access: 'There is an underlying assumption that maximum participation in HE will contribute to the well-being of society. There seems to be an acceptance that a university degree is something that not only one third, but nearly one half of the population, can achieve.'

Forth thinks that the blind expansion of HE will lead to the further degradation of standards: 'Surely the great danger of the era of "one in two of the population as graduates" is that the degree will be devalued and undermined.'

You might think that is rich coming from a Conservative MP who, as a minister for education in the previous government, helped to introduce many of the measures which have contributed to the degradation of HE. But it is just a shame that it has been left to Tory has-beens to defend academic standards, while lecturers, professors and

government-appointed officials are busy overseeing their further degradation. Whatever we might think of Eric Forth, he is surely right that cramming as many students as possible into higher education, regardless of their qualifications and suitability, is posing a significant threat to academic standards.

What is really being questioned in the debate about widening participation is the idea of externally-set standards or, as it used to be known, universal knowledge. Today's radical educationalists object to the notion that there is a universal standard of excellence to which all students, from whichever social class, should aspire. Universal knowledge is frowned upon as elitist and stuffy and hostile to the experience and understanding of working class students, women, ethnic minorities and the disabled. But relativising knowledge will do nothing to inspire students and a lot to lower standards. In fact, it is only the existence of a universal standard, against which everybody can be judged on merit rather than social status, which offers working class students the opportunity to fulfil their real potential.

Patrick, 22, recently graduated from Manchester University with a 2:1 in Accountancy and Finance. Growing up in Burnt Oak, a working class suburb in north London, Patrick was always aware that there were inequalities in the education system. 'I grew up just a bus-ride away from Harrow, in fact I could see Harrow-on-the-Hill from my bedroom window, with its clusters of schools. We always knew that the pupils at Harrow could afford the best education in the country and that they would all go on to better things, while the rest of us had to make do with second-rate teaching.'

But Patrick was determined to make it to university and got two A's and a B in his 'A' levels. 'I was over the moon with my results, it meant that I could also go on to university and to better things.' The important thing for working class students like Patrick is that they are tested on equal terms with every other student in the country, whether they be at Eton, Harrow or an inner-city comprehensive. In this way working class students can prove their worth and develop their potential.

By contrast, lowering standards in the name of widening participation can only rob working class students of the opportunity to prove that they are as good as anybody else. More people may emerge at the end of their education with a degree certificate, but what will it be worth to them? It is unlikely to prove to be their ticket to a better job and the good life; already, many graduates are having to fill the kind of boring clerical jobs that an 'O' level school leaver would have been doing not so long ago.

The exclusive and elitist education system of the past was by no means perfect. But rigorous examinations in the name of exclusion allowed universities to select the best students, to develop their full potential and to raise academic standards. By contrast, shifting the balance in favour of inclusion, through easier entrance requirements and without raising the level of pre-university education, will lower standards and benefit nobody—least of all working class students who really do want to escape their 'lower socio-economic backgrounds', and make something of themselves by their own merits. ●

Former able-seaman (RN) Dave Hallsworth recalls when atrocities were not called war crimes, because they were committed by US soldiers

# THOSE WHO LIVE IN GLASSHOUSES...

**W**atching the judges of the new war crimes tribunals in Europe and Africa deliberate over who is guilty of 'crimes against humanity', I recalled the time nearly 30 years ago when the USA had to put its own soldiers on trial on similar charges—and let them off, of course.

In 1968, US troops wiped out the entire Vietnamese village of My Lai within four hours. The army kept the My Lai massacre secret for 18 months. After news finally leaked out in November 1969, Lieutenant William Calley (the officer commanding the attack) was tried (at the US army's own court martial) on charges of killing at least 109 'Oriental human beings'. Sentenced to life with hard labour in 1971, Calley appealed three times, and each time his sentence was reduced, culminating in his release in 1975. On the orders of President Richard Nixon, he served his short sentence under 'house arrest' in an army flat. Calley did not spend a day in prison.

Compared with the confusing cocktail of hearsay and 'expert' opinion at the war crimes tribunals, the testimony given at the Calley court martial was a clear-cut and candid first-hand account of cold-blooded mass murder. Read a few extracts, and ask yourself what is a war crime anyway?

#### Court martial testimony of Private Paul Meadlo:

Q What did you do?

A I held my M-16 on them.

Q Why?

A Because they might attack.

Q They were children and babies?

A Yes.

Q And they might attack? Children and babies?

A They might've had a fully loaded grenade on them. The mothers might have thrown them at us.

Q Babies?

A Yes.

Q Were the babies in the mothers' arms?

A I guess so.

Q And the babies moved to attack?

A I expected at any minute they were about to make a counter-balance.....

Q What happened then?

A He [Lieutenant Calley] started shoving them off and shooting them in the ravine.

Q How many times did he shoot?

A I can't remember.

#### Court martial testimony of Private Gene Oliver

Q Did you see any dead Vietnamese in the village?

A Yes sir.

Q How many?

A Most of them. All over.

#### Court martial testimony of Private Richard Pendleton

Q Can you describe what you saw?

A There was a large mound of dead Vietnamese in the ditch.

Q Can you estimate how many?

A It's hard to say. I'd say 40-50.

Q Can you describe the ditch?

A It was seven to 10 feet deep, maybe 10-15 feet across. The bodies were all across it. There was one group in the middle, and more at the sides. The bodies were on top of each other.

#### Court martial testimony of Private Charles Hall

Q How did you know they were dead?

A They weren't moving. There was a lot of blood coming from all over them. They were in piles and scattered. There were very old people, very young people, and mothers. Blood was coming from everywhere. Everywhere was all blood.

#### Court martial testimony of Lt William Calley

Q What were they firing at?

A At the enemy sir.

Q At people?

A At the enemy, sir.

Q They weren't human beings?

A Yes sir.

Q They were human beings?

A Yes, sir.

Q Were they men?

A I don't know, sir. I would imagine they were, sir.

Q Didn't you see?

A Pardon, sir?

Q Did you see them?

A I wasn't discriminating.

Q Did you see the women?

A I don't know, sir.

Q What do you mean, you weren't discriminating?

A I didn't discriminate between individuals in the village, sir. They were all the enemy, they were all to be destroyed, sir.

#### Court martial testimony of Private Frank Beardslee

Q Did you receive any hostile fire at all any time that day?

A No, sir.

#### Court martial testimony of Private Salvatore La Matina

Q What were your orders?

A Kill anything that breathed.

#### Court martial testimony of Private Dennis Conti

Lieutenant Calley came out and said take care of these people. So we said, okay, so we stood and watched them. He went away, then he came back and said, 'I thought I told you to take care of these people?'. We said, 'We are'. He said, 'I mean kill them'. I was a little stunned and I didn't know what to do...I stood behind them and they stood side by side. So they—Calley and Meadlo—got on line and fired directly into the people...it was automatic. The people screamed and yelled and fell. I guess they tried to get up too. They couldn't. That was it. The people were pretty messed up. Lots of heads were shot off. Pieces of heads and pieces of flesh flew off the sides and arms.

#### Private Varnado Simpson, quoted in *Four Hours in My Lai*

I just went. My mind just went...I just killed. Once I started the...the training, the whole programming part of killing, it just came out...

I just followed suit. I just lost all sense of direction, of purpose. I just started killing any kinda way I could kill. It just came. I didn't know I had it in me.

#### Court martial testimony of Private Robert Maples

Q Did you open your pants in front of a woman in the village of My Lai?

A No.

Q Isn't it a fact that you were going through My Lai that day looking for women?

A No.

Q Didn't you carry a woman half nude on your shoulders and throw her on the ground and say that she was too dirty to rape? You did that didn't you?

A Oh, yeah, but it wasn't at My Lai.

Anybody who thinks that warfare is other than this, is living in a pipe dream. 'War crimes' are defined not by the degree of barbarity, but by who pulls the trigger. If you come from a poor country, you are in danger of being branded a war criminal; if you come from the West, you are likely to be let off or even honoured.

And don't think the British are any better than the Americans. In 1949, I served on HMS Jamaica transporting the 41st Royal Marine Commandos to Penang, Malaya, where the rebels were fighting for independence from the Empire. About a week after we arrived the marines invited us to go on patrol with them. We went on an armoured train to Kuala Lumpur. While on patrol they stopped at a village which was said to be providing food and shelter to insurgents. The marines found the two elders, tied them to a tree and slit their stomachs open with machetes, so their intestines fell out. Then they marched the village past them. A sailor by the name of Bertie Bell took photographs of this, but when he got back to the ship they were confiscated by officers. Of course, nobody was accused of war crimes; they were just Royal Marines, doing their job for Queen and Country. ●

#### Sources:

Report of the Department of the Army, Review of the Preliminary Investigations into the My Lai incident, Volume 1, 14 March, 1970, Report of the Peers Commission in Richard Hammer, *The Court Martial of Lt Calley*, 1971; CBS *Evening News*, 25 November 1969 in Michael Bilton and Kevin Sim, *Four Hours in My Lai*, 1992

Reports which claim new evidence that videos can cause violence are more fanciful than factual, says Andrew Calcutt

## 'A SCIENTIFIC CASE FOR CENSORSHIP'?

**O**fficial: violent videos cause crime' announced the *Sunday Times* front-page headline (17 August 1997). After years of debate about the effects of screen violence, 'Home Office researchers have established the first official link between crime and screen violence'. The report concluded that a two-year study by forensic psychologists Dr Kevin Browne and Amanda Pennell at the University of Birmingham 'makes out a scientific case for stricter censorship'.

The triumphant tone of the *Sunday Times* story was at odds with a press release about the study, issued by the University of Birmingham itself the following day. Noting that 'one hypothesis of the research is that those youths who have grown up in a violent family will remember more details of the violent and aggressive acts portrayed' which 'may have the consequence of making their own aggression more frequent', the press release conceded that 'statistical and scientific analyses of these concepts have yet to be conducted to confirm or refute this hypothesis'. Browne's analysis is due to have been completed in time for publication of his full report this month (October).

In the wake of the alleged link between the video of *Child's Play 3* and the murder of two-year old James Bulger in 1994, the Home Office commissioned Browne to carry out a study of the effects of video violence on young offenders. Browne interviewed 40 violent offenders, 40 non-violent offenders and 40 non-offenders, all males aged between 15 and 21. He showed them a film and questioned them about their recollections of it. In August of this year, the *Sunday Times* learned from the Home Office that Browne's report was close to being published.

The subsequent story was published under the byline of Nicholas Rufford and Nicholas Hellen, who has covered this area for the paper for years. It quoted Browne as saying that 'videos cannot create aggressive people but they will make aggressive people commit

violent acts more frequently'. This is in keeping with Browne's contribution to a 1995 *Panorama* programme on claims that Oliver Stone's *Natural Born Killers* induced 'copycat killings'. Then he said that it 'would be wrong to say that people who watch violent material are going to be violent'; but 'a small number of the population is predisposed to be aggressive when they're frustrated or in a situation of conflict. For that 3-10 per cent, these films are unhealthy'.

The text of the *Sunday Times* account of Browne's research stops short of making a simple causal connection between violence on screen and off. But it is suggested in the headline 'Official: violent videos cause crime'; and this was the creative reading of Browne's research which swiftly passed into the realm of common sense. Browne made no further comment to the press, and the University of

young more violent". The *Mail's* editorial was jubilant: 'Common sense tells you it must be so, and now academics commissioned by the Home Office have proved it. Violent videos *do* cause crime.' (18 August) The causal connection erroneously ascribed to Browne's research quickly passed into media folklore. In a story on a booklet published by the National Society for the Prevention of Cruelty to Children advising parents about young people's viewing habits, the *Guardian* mentioned in passing that 'this most recent study has found a link between videos and violent crime', and Elizabeth Newson, author of the notorious Newson 'report' which gave pseudo-scientific credence to calls for more censorship in the wake of the Bulger murder, castigated the NSPCC for 'shilly-shallying around and saying there is no proven link when research proves this exists' (3 September).

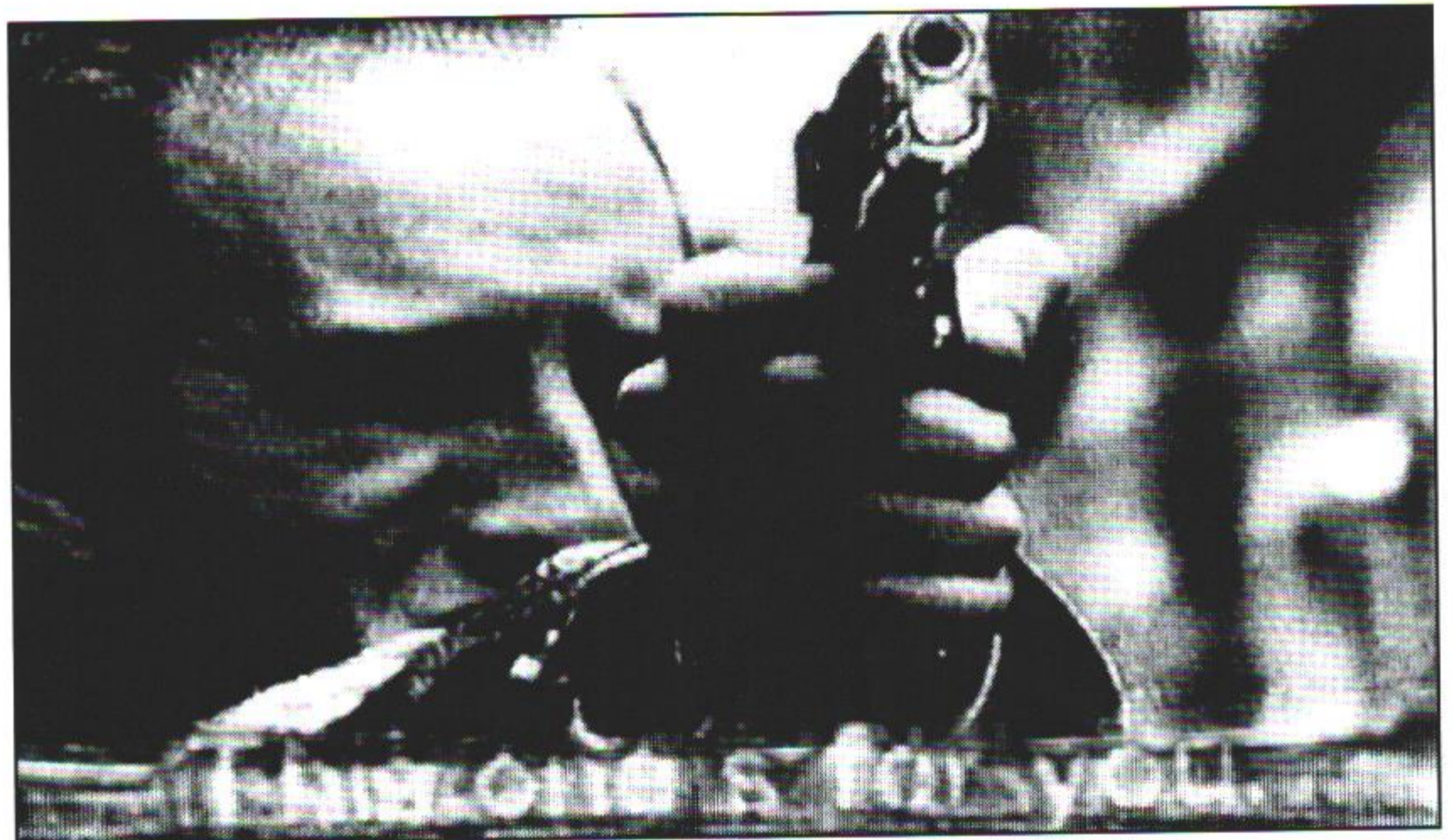

Birmingham statement was presumably issued as a spoiler. But the idea of a causal connection had already become 'official'; and when media studies academics complained to the *Sunday Times*, their protests went unreported.

The 'effects' bandwagon was rolling once again. The day after the *Sunday Times* story, the *Daily Mail* announced that 'Study links screen savagery to real-life attacks. Movies "can make

The Browne research has been reported as a highly innovative piece of work which finally delivers the *coup de grace* to the 'liberal, media studies agenda' against censorship. Yet Browne's hypothesis, referred to in the Birmingham statement, represents a retreat from the unequivocal pro-censorship position, now recognised as scientifically untenable, that screen violence per se causes



real-life violence. Instead, Browne suggests that screen violence may have an exaggerated effect on a small minority whose upbringing has rendered them peculiarly susceptible. But the grounds for making even this claim are as spurious as the case for a causal effect on general behaviour.

Browne's provisional conclusions seem to be twofold: that on-screen violence is more readily remembered by violent offenders; and that, as he said to *Panorama* in 1995, 'children that come from a violent background... have poor understanding of others and poor empathy with others, and their moral development may be slow. They will transpose their own experiences into certain scenes... and that's how they are reading the film differently to a non-offender'.

Browne's findings may show that, when interviewed, his sample of 40 violent offenders was more likely to recall violent incidents on-screen. But what of it? Showing one film to 40 people (under-18s watched a certificate 15 movie, while the 18-21s viewed a certificate 18 film) and asking them about it (immediately afterwards, 3-4 months later and 9-10 months later) in circumstances which, judging by the *Panorama* footage showing Browne at work, resembled a youth club discussion group, hardly constitutes incontrovertible evidence of the mindset of violent offenders. The responses of the 40 violent offenders could indicate merely that they had more experience of giving interviewers what they thought was required of them.

Besides, in and of itself the ability to recall instances of screen violence says nothing about subsequent behaviour. The people with the most encyclopaedic memory for celluloid gore are horror movie buffs like Mark Kermode, film critic for Radio 1 and contributor to horror fanzines such as *Fangoria*, also known as 'Exploding Heads Monthly'. As yet, the police are not scouring conventions of horror film fans in search of axe-murderers.

The claim, that those who have been witnesses to violence or victims of abuse during childhood are predisposed to perpetrate acts of violence themselves, is hotly disputed. Such claims are usually based on self-reporting by violent offenders or their parents, not the most reliable sources. Furthermore, for every 'aggressive' adult who experienced violence in childhood, there are at least as many child-victims who display no such tendencies in later life. The 'cycle of violence' theory, which closely resembles the biblical notion of the sins of the fathers being visited upon their children, has no substance.

The two halves of Browne's hypothesis amount to not very much. Moreover, they are only brought together by the conjecture that violent scenes 'excite them' (the 3-10 per cent), and 'trigger their memories, and because it's so real for them that triggering off their memory may also trigger the need to do it again' (*Panorama* interview, 1995). It would be equally valid to ruminate that experience of violence in childhood is likely to underline the desire to avoid violence in later life. But in Browne's case, the 'cycle of violence' theory has been used as a springboard from which to make an illegitimate leap from the retention of images of fictional violence in the memory, to the alleged propensity to perpetrate violent acts in real life.

As we go to press, Browne's research has not been formally published, but already it, and the conclusion ascribed to it, are fixtures of political debate. Lord Alton (formerly David Alton MP) will take the opportunity to resume his campaign for 'higher standards in film and video'; and videos deemed violent (excluding, presumably, patriotic war films) are likely to be barred from young offenders institutions. Meanwhile, against a background of renewed concern about the alleged effects of violent videos, Jack Straw has let it be known that the Home Office will keep a tighter rein on the British Board of Film Classification, the censoring body which has hitherto been formally independent of government control. All this on the basis of simplistic coverage of what seems a flawed report.

In today's climate, the hypothesis that videos contribute to violence does not need to be backed up by hard evidence. It is automatically accepted as true because it connects with the wider mood of the times, when many are given to believe that other people are lowlife who cannot rise above their circumstances or keep their heads in the face of media images.

In fact, the police officers investigating the murder of James Bulger discounted the influence ascribed to *Child's Play 3*, pointing out that the two boys who killed Bulger had never seen the film. But more than three years later, the *Sunday Times* report spoke unquestioningly of 'concern about the role of screen violence in influencing the child killers' which prompted the Home Office to fund Browne's research. In the same way, the Browne report, regardless of how much or how little evidence it contains, is guaranteed a good press as an advert for further censorship, in the country that already has Europe's toughest controls on the contents and distribution of videos.

# FUTURES

*New Labour wants to swap the 'car culture' for an 'integrated transport system'. Austin Williams wants to know how these fine-sounding words will help us to get about more easily*

## ON THE ROAD TO NOWHERE

One of the first acts of the New Labour government was to merge the Transport and Environment portfolios into one super-ministry. Headed by John Prescott, the new department immediately announced its commitment to an integrated transport strategy. On World Environment Day in June, Prescott received a tremendous ovation for a raft of proposals intended to encapsulate 'the highest aims for our transport system'.

The idea of coordinating services to provide a genuine choice for travellers is something that anybody with an interest in transport would want to support. The possibility of travelling conveniently by public transport to any point in the country (and beyond), has long held a place in the daydreams of those standing in rainy bus queues. No more waiting hours for your connection, no more rushing for the last bus: each step of the journey would be linked by inter-transport nodes which would coordinate services for maximum efficiency.

Of course, public transport could never be as flexible nor immediate as the motor car. However, a highly developed public transport system would have its own advantages: faster over long distances; less hassle in many cases; more freedom for the traveller to do other things on the journey. For once, the erstwhile car driver would have the chance to indulge in the pleasures of the

scenery. There seems little doubt that a much improved public transport system would tempt car owners to leave the car at home at least some of the time—I am certainly all in favour of letting the train (hovercraft, helicopter or monorail, for that matter) take the strain.

It would seem clear that the one thing required to improve and integrate the public transport system is investment, and a lot of it. However, despite the rhetoric, it is not on the government's agenda to spend any extra money on transport. Chancellor Gordon Brown's July budget made it plain that there will be no new public money for transport investment and that existing resources will have to be allocated more prudently. Yet nobody seems too upset about this. Transport Secretary Gavin Strang reassured everybody that Brown's austerity budget was in fact a ringing endorsement of his plans. And when I spoke to representatives of interested lobby groups to gauge their reaction to the government's proposals, they tended to be supportive and did not mention the need to invest in improving public transport:

'We welcome Labour's proposals although we are concerned that they are not undermined by short-term decisions. In the long run we look forward to tougher demand management in terms of parking taxes and road policy.' (Stephen Joseph, Transport 2000)

'We welcome the moves towards an integrated transport strategy, although there were many missed green tax opportunities in the budget.' (Alan Francis, Green Party)

'We are in favour of integrated transport, but Labour will need to consider any decisions that will work

against it. For example, the relief road-building programme and the continued construction of out-of-town developments.' (Roger Higman, Friends of the Earth)

Gone were the visions of improved services. Instead, they all spoke of the need for increased penalties and prohibitions on the car. Why? Antipathy to what is called the 'car culture' has become so ingrained that attacking car drivers is seen as a positive contribution to transport policy, and to public transport policy in particular. The mentality appears to be that cars and public transport are in competition, so a setback for the former is necessarily good for the latter, even if in reality car drivers are simply being penalised while public transport is left in the same sorry state as it was before.

Within only 100 days in office, Gavin Strang had already halted construction of two major road-building schemes and put a hold on a further five. Under pressure from environmental lobbyists, the government is actively considering road tolls, company car levies, flat rate payments for city-centre road users, and much, much more. For the new government, demands from environmental and public transport campaigners for big cuts in the road-building programme and financial penalties for motorists must seem too good to be true. Labour is in the enviable position of allowing the lobbyists to

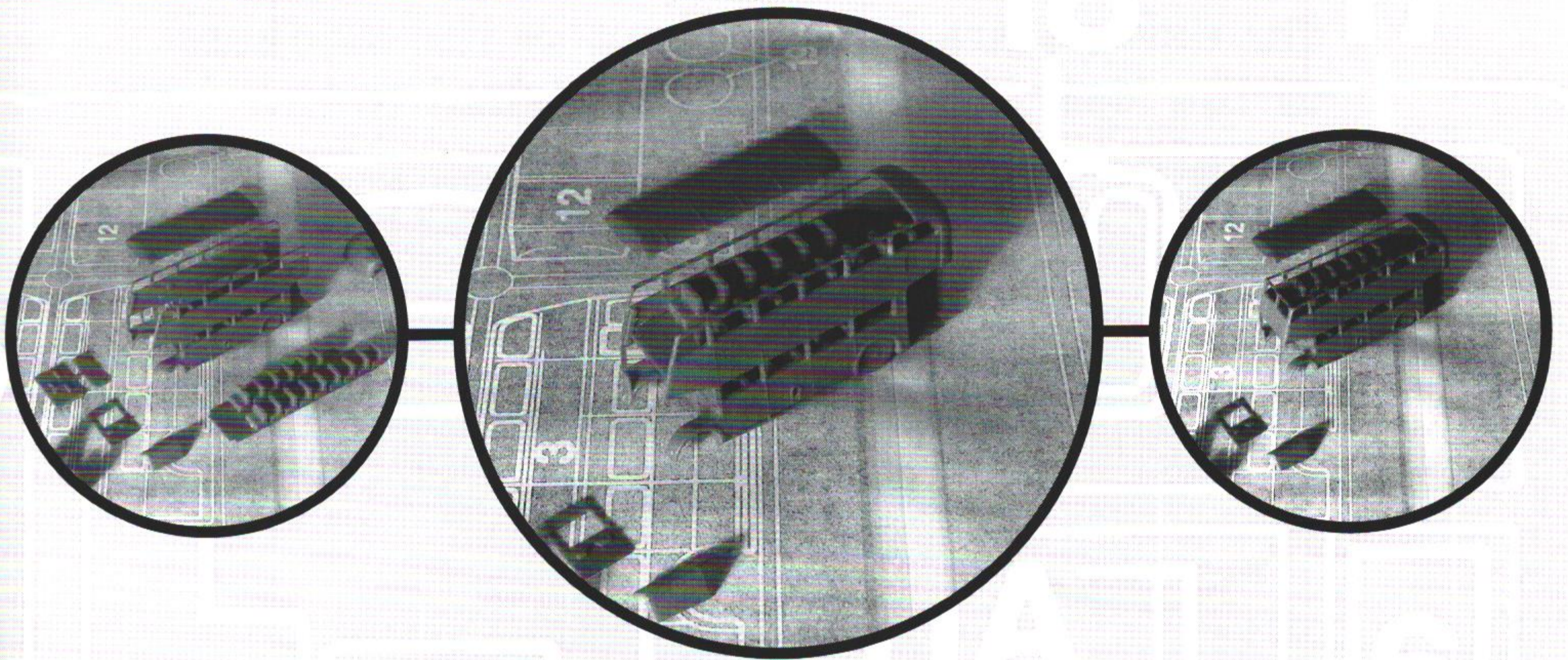

come up with all kinds of wheezes to save money, while the government can appear slightly more moderate by only introducing some of the austerity proposals.

Prescott has launched a consultation paper, 'Developing an integrated transport policy', which calls for everybody to contribute to framing future transport strategy. To avoid any far-fetched suggestions—such as an injection of cash—the document gives a few pointers as to the direction that the debate should take: 'Recognising that funding available from the public purse is strictly limited, how best do you think our transport systems could be improved?...What balance should there be between "sticks" and "carrots" to achieve our aims?' Carrots can be expensive, but Labour need not worry; the sticks it needs to beat the motoring public grow on trees, nurtured by the supposed proponents of decent public transport systems.

How can it be that cars and public transport are in competition? Admittedly, cars and buses use the same roads. However, surely, even here, critics of the car should be arguing that more money spent on buses, perhaps with lower fares, is the way to get people out of cars. Instead, they have all but ignored the issue of investment and declared that they are fully behind—or rather some way in front of—the government's attack on the 'car culture'. Why? Because critics of the car are really critics of car drivers.

The environmentalist view is that drivers are irresponsible, anti-social and so wedded to car use that shock treatment is required to break their dirty habit. While environmental lobby groups often disguise their criticism of the car with demands for improved public services, they tend to agree with the government that it would be foolish to introduce measures for cheaper, better and more frequent public transportation while we are still 'psychologically wedded' to the car. Who would catch a bus while the car remains a viable alternative, runs the argument. The notion that we have to tackle the dominance of the car culture before investing in public transport is a strong theme of the discussion these days.

Congestion has become the new bogey (*That's enough snotty puns—Ed*). We are forever being told that there is too much traffic on too many roads. Curiously though, nobody seems to know how congestion is determined. When I phoned New Labour's Transport Policy Unit, responsible for drafting mandates on this issue, a spokesman could only read me the dictionary definition: 'an abnormal accumulation or build up....for example, blood clots....' Hmm, I see. However, the term's vagueness seems to be its strong point. The anti-car lobby need only state that there are unsustainable numbers of cars on the road and no further substantiation is required. Public transport and private cars are then seen as competitors for ever decreasing road space.

The only thing that will be improved by penalising car users while not investing more in public transport will be the Treasury's revenues. It will do nothing to improve transport. In the past, the theoretical solution to high density traffic flows was, first, to give

careful consideration to the strategic requirements of each specific case, and then to improve the infrastructure to overcome the problem. Today, however, this is seen as irresponsibly utopian. Since there is an unquestioned assumption that there are too many cars on too many roads, it follows that building more infrastructure will only delay, or exacerbate, the problem.

Rather than building more infrastructure, transport commentators recommend that we should reduce demand, to nip the problem in the bud. Amory Lovins' Hyper-car prototype exemplifies this new agenda. This 500kg, 5-door concept car, powered by 'hybrid-electric' propulsion, can travel in excess of 300 miles on one gallon of petrol. Carbon dioxide emissions are not even an issue. But even here, rather than give their unreserved endorsement to this technological achievement, its developers point out that one of the more 'undesirable' side effects of the Hyper-car is that, because it is so attractive, more people will want to drive it! Understandably, if too many cars is the problem, fewer cars is the answer.

Congestion, or more perversely, over-congestion, is used as a shorthand way of discussing the allegedly detrimental social impact that cars, and the roads upon which they drive, have on residential and rural communities. According to some researchers, roads have become a virtual Berlin Wall in

## Car drivers are being set up as the smokers of the New Millennium, banished to the margins of the city

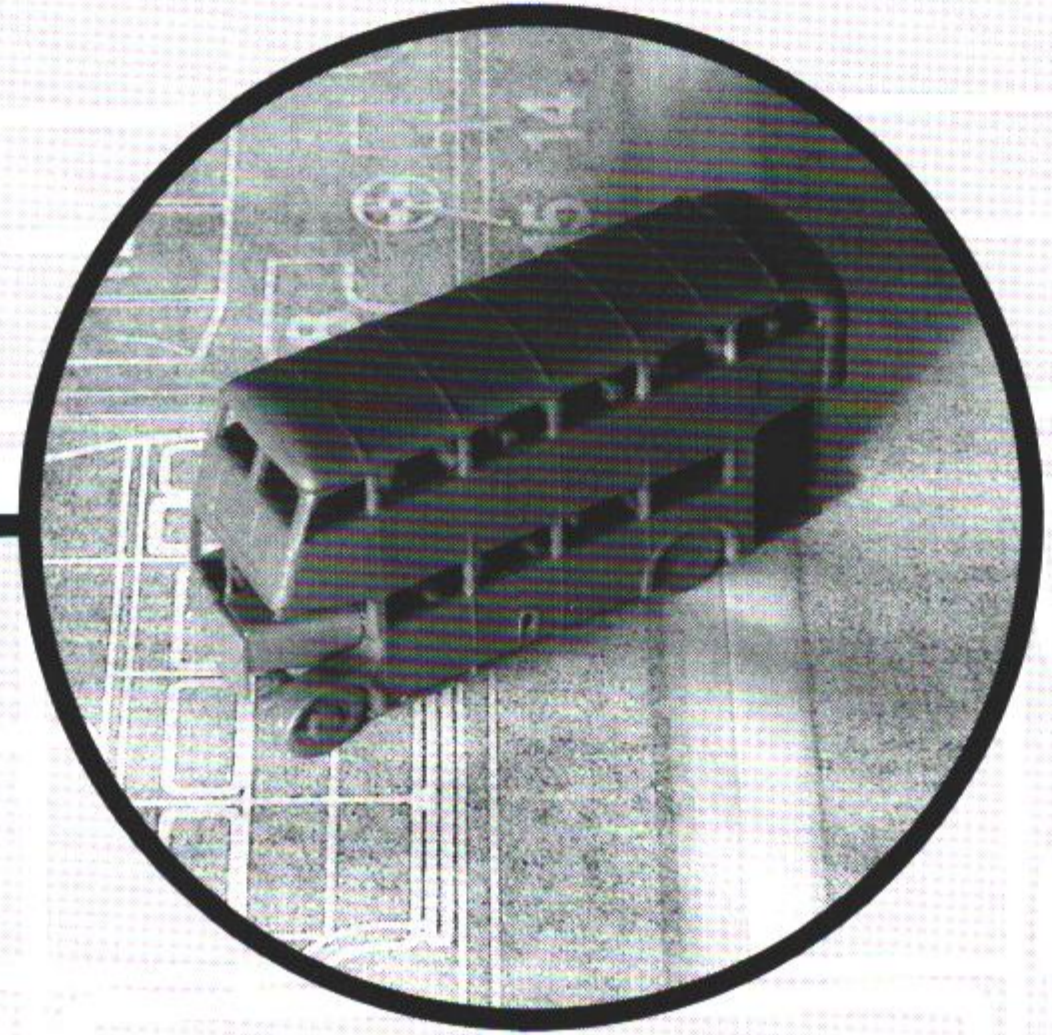
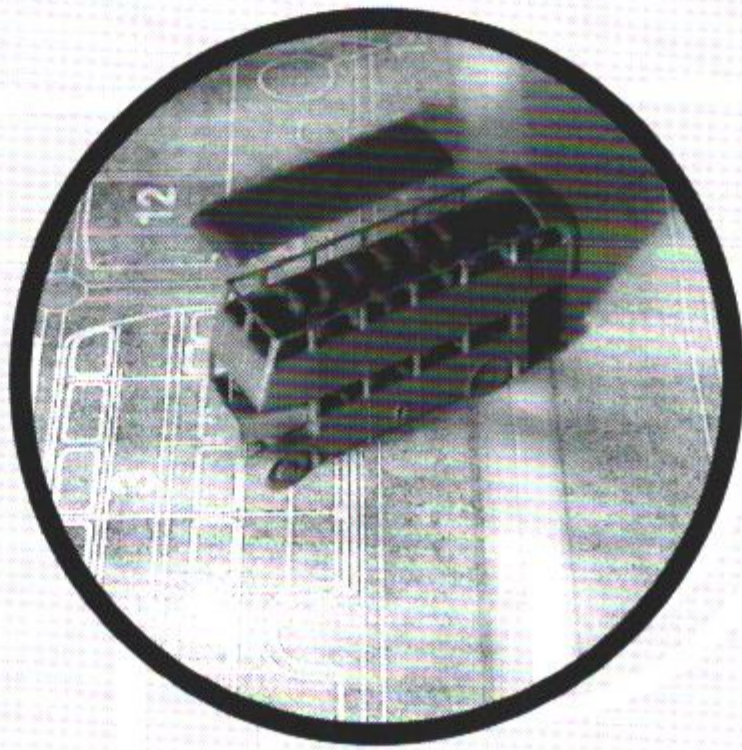

many areas, separating friends and families by an impenetrable wall of traffic. (Haven't these people heard of Pelican Crossings?) In his influential booklet, 'Unlocking the gridlock', Christian Wolmar—political, and formerly transport, correspondent for the *Independent*—shows his rather shaky grasp of both specialisms: 'Main roads, in effect, create barriers within or between communities almost as effectively as does the religious divide in Northern Ireland. 'Excoriating the car as a symbol of Thatcherite individualism is deemed to be a precursor to building a more humane society. Some transport experts have even floated the idea of jitneys, Third World minibuses crammed to the point of over-flowing, as a positive example of community-building social transport.'

The idea of an improved, modern public transport system has disappeared from the debate. Instead we are treated to sermons about the individual and community, health benefits of life in the slow lane, and offered the squalid, impoverished Third World model of transport as a step towards a 'more humane society'.

'Live the impossible dream', says National Bikes newspaper, *Lifestyle*, 'Eat yourself silly, and still lose weight!'. 'Burn fat, eat well, and live longer.' Under New Labour, you can have your cake and eat it provided you follow a healthy regime of vigorous exercise afterwards. Within the limited

world-view of environmentalists, cycling and walking are promoted as exciting transport alternatives. Sustrans, the National Cycle Network, has been allocated £42.5 million by the Millennium Commission to construct 6500 miles of cycleways by the year 2005. Cycling may be an enjoyable leisure pursuit, but it is now being promoted as a local substitute for the car. 'The routes now being created will help civilise local communities', says Jeremy Paxman, patron of Sustrans.

Underpinning this cosy notion of genteel civility lies an authoritarian social contract. Mechanisms to permit only 'responsible driving' are already in place. It is taken as read that there should be higher fuel charges to reflect the real 'social' costs of motoring. (These costs include such things as NHS treatment for asthma sufferers and accident victims, traffic wardens' wages, parking meter maintenance, etc). Road tolls are soon to be introduced. A number of councils have followed Camden's example and introduced 'no-car tenancies' which means that if you own, or subsequently purchase, a car, you may be liable for eviction.

The government is giving serious consideration to pay-as-you-drive schemes, while Newcastle and Edinburgh are planning to ban cars from their city centres altogether, with hi-tech CCTV surveillance at entry points to ensure compliance. There are numerous other examples of how local authorities are wilfully increasing congestion through town-centre redesign, in order to 'persuade' die-hard drivers to use the bus. Insidious suggestions include a prohibition on rush hour traffic on the M5 and M6 near Birmingham and the closure of some of London's roads and bridges to cars, done to teach us a lesson by actually

increasing congestion elsewhere. Car drivers are being set up as the smokers of the New Millennium, banished to the margins of the city.

The debate around an integrated transport system has little to do with public transport and absolutely nothing to do with helping us get about more easily. The ideals have been subsumed into a moral campaign to change individual behaviour and to reforge a sense of community. People's real transport needs are being put on hold, while the government concentrates on breaking the supposedly irresponsible reliance on the motor car today. If we want decent infrastructure, it now seems, we will have to show John Prescott and Gavin Strang that we can be trusted. It is up to us to prove ourselves worthy of public transport.

Surely, if we want to achieve a healthier environment and better transport system, we should be striving for increased investment in better technologies, to integrate infrastructural projects so that they provide a decent level of accessible services. This is not inconsistent with the use of the private motor car, the single development in transport which has done most to liberate people in the twentieth century. But try telling that to a government intent on demonising car users as irresponsible, and so finding a scapegoat for the transport problems brought about by underfunded crumbling public services.

Speaking at a much-publicised national conference on alcopops, Jennie Bristow uncovered the professionals' hidden agenda

# A NATION OF ADDICTS?

**Y**ou can't just ban alcopops—what difference will that make? Alcohol Concern has never called for a ban on alcopops.' Mary Ann McKibben, the main 'alcopops person' at Alcohol Concern, was the first to address the seminar *Alcopops: New Drinks, New Dangers?*, held by the Addictions Forum on 18 August. As she spoke, you could almost hear the curses and the closing of notebooks as the national media reporters prepared themselves for a wasted day. No bans, no prohibition, nothing newsworthy said at all.

Next up was Sarah Berger from Drinkline, the national alcohol helpline launched by the health ministry four years ago. 'Drinkline is not anti-alcohol, not prohibitionist, not abstinence-orientated. I'm not actually totally opposed to all alcopops: some of them are rather nice. They are not the major cause of underage drinking, or a major cause of the moral decline of youth today.' Now it was my turn to start cursing under my breath.

I looked down at the speech I had been asked to prepare in defence of alcopops. It is a moral panic, there is no evidence proving the link between alcopops and underage drinking, bans will not work.... That was the gist of the first three pages. Yet the very groups who have been most vociferous in condemning alcopops and calling for more regulation had said it for me. And the audience—the vast majority of whom were delegates from local drug and alcohol advisory groups—went along with it, smug in the knowledge that they had managed to pull off a significant con-trick which swept the media, politicians and many other sections of society along with it.

So what, I wondered, were they all doing there? Sarah Berger explained. The panic about alcopops, she said had 'given Drinkline, and others, a golden opportunity to use the media furore to talk about our own agenda'. But if a campaign against alcopops is not the real agenda of alcohol concern groups, what could that agenda possibly be?

## Define 'adult'

It certainly was not anything so straightforward as dealing with a few alleged addicts. Almost every speaker called on us to put alcopops 'in context' and pay attention to 'the broader picture'. So you cannot just deal with alcopops, or young people. You have to deal with young people's role models, their parents, their education. You have to deal with underage drinking as an all-encompassing social problem. In other words, you have to deal with everybody as a potential addict, and regulate the drinking behaviour of society as a whole.



ILLUSTRATION: ICE

Having twigged this, I changed tack and argued that the problem with restricting the product itself was a restriction of adults' choices. There is already a law against buying alcopops under the age of 18, I said, and kids will just drink something else. Adults should have the freedom to make choices, and the restrictions on alcopops treat them like children.

Now that was controversial, but not for the reasons I had anticipated. Yes, the forum could see that kids would drink something else: as some research presented by a PhD student at the University of Glasgow showed, vodka and white cider are still the most popular drinks for teenagers, because they get you very drunk very quickly very cheaply. But the experts all wanted to dispute my apparently controversial suggestion that over-18s should be treated as adults rather than children.

When a member of the audience asked, 'what is your definition of an adult?', I have to confess to being slightly flummoxed. Does the law not make it obvious? Apparently not. After much debate, the conference agreed on a working definition of 'young people' as being the 13-25 age group. My 22 years of life experience seemed to fall away as I realised that I was part of the problem—that 'underage drinking' had suddenly come to mean anybody under 25 drinking alcohol. And, as I was reminded, one had to be very careful in assuming that adults—particularly young adults—were rational, responsible and able to make choices. After all, 50 per cent of the prison population are young men, and there are a lot of people out there who behave like children after their eighteenth birthday.

## 'Health is freedom!'

'But what about freedom?', I asked. How can adults have rights and freedom if they are seen as too irresponsible to buy an alcopop? And they did laugh. As Dr Lynne Friedli from the Health Education Authority advised me in the break, 'Health is the most important freedom we can have'; rights and choices are all a capitalist con, apparently, and giving them up is a small price to pay for being healthy.

But is it? Those at the Addictions Forum may admit that the concern with alcopops is a moral panic, but it has been a panic with consequences. Some shops and pubs have banned alcopops, some only sell them under the counter, and others have brought in extra rules—as discovered by my 26-year-old friend, refused some bottles of Hooch in Sainsburys until he showed his driving licence. As the alcopops industry becomes increasingly defensive, and retailers' feet get colder and colder, it will not be long before it is easier to buy cannabis on the street than it is to buy an alcopop in a supermarket.

The campaign against alcopops has now assumed a wider significance. If customers are deemed incapable of handling an alcopop, what else might retailers withdraw as 'irresponsible'? Since when have supermarkets and alcohol addiction groups had the authority to act as society's moral guardians, responsible for telling people what they can and cannot drink?

In slating the alcohol industry, Mary Ann McKibben argued that the reaction to alcopops was a slap in the face to all those who believed the public to be so 'completely stupid' as to be taken in by the claims that alcopops are not aimed at young people. At least the drinks industry trusts its customers to make decisions about what they buy. The same cannot be said for those who argue people are 'vulnerable to abuse'—a euphemism for 'completely stupid'. ●

# a l t . c u l t u r e . s p o r t

Carlton Brick on a new book that suggests why even  
Tony Blair now wants to pose for photos in a football shirt

## Signs of the times

**'What about all the children who will grow up never knowing her?'**  
wailing mourner at the Diana vigil speaking to GMTV reporter

**'If one is endlessly judging every single picture—one by one—the tension is so great one feels like having a wank!'**  
Art critic Brian Sewell describes the joys of being part of an awards panel

**'When visiting the surrounding area, please act with courtesy at all times'**  
ticket message at the Romney Marsh Hell's Angels convention.  
Octogenarian former *Daily Telegraph* editor Bill Deedes is a regular visitor, and a great admirer of the Angels' discipline, though he admits he is 'not much into leather studded gear'.

# USING OUR RELIGION

**N**ot so long ago football and the football fan were considered the lowest of the low. Foul-mouthed, violent and uncultured, we were the dirt on society's shoe. But nowadays the politicians who poured scorn on the game cannot wait to get their kits out for the lads. Edited by Gary Armstrong and Richard Giulianotti, *Entering the Field: New Perspectives on World Football* offers some insights into this transformation.

*Entering the Field* looks at the role of football in countries as diverse as Argentina, Italy, Palestine, Scotland, and the USA. Eschewing both the simplistic studies of 'hooliganism' and the platitudes of the Hornbyesque school of 'new football' writing, the essays edited and introduced by Armstrong and Giulianotti shed light on what they call 'the politicisation of football and the footballisation of politics'.

According to Armstrong, in Britain the previous discussion about football has been dominated by 'an overriding concern with controlling and criminalising spectators'. Giulianotti believes that 'new insights have been afforded by bringing in individuals

'convenient form of cultural "distinction", for marking off this privileged social caste in class and ethnic terms'.

In Europe the 'footballisation of politics' is also well developed, as in the case of Italy's Silvio Berlusconi, the former prime minister and owner of Serie A giants AC Milan. In the early nineties the mushrooming of Berlusconi's post-political movement Forza Italia provided a vivid example of the attempt to use football and the media to engage with an electorate which has had its fill of both left and right wing ideologies.

Drawing on a wide range of experiences from different parts of the world, Armstrong and Giulianotti demonstrate the key factor in the political mainstreaming of football: from war-torn Africa to white Middle America, football has become a metaphor for the desire to create new forms of political legitimacy, and a dramatic representation of the search for new moral identities.

With this in mind, it is easier to understand recent developments in Britain. Where once the discussion of football consisted of nothing

# BOXING KO'D



PHOTO: DAVE CHAPMAN

**'Rastafarian-type persons do not wish to co-operate with the police'**

Inspector John Chandler, explaining why everybody except the suspect was wearing make-up and a wig in an identity parade at Gloucester

**'I'm intrigued at how people react to someone dressed in costume', said Brian Cheeseman, a university lecturer in children's play. Not too well, it seems. He was ejected from Headingly cricket ground while dressed as a carrot. He was accused of being drunk and disorderly, a charge he strenuously denies.**

**Twenty-two policemen from various forces are to be charged following 'unacceptable behaviour' with a stripper, including licking chocolate from her body.**

**Police on Tyneside are electronically tagging children's replica football shirts. Apparently there is a crime wave involving thefts from washing lines.**

# Football is our Religion



**We know how you feel. We feel the same way.**

PHOTO: COURTESY OF B SKY B

**O**n 25 June 1997, Bury Metropolitan Council became the first local authority in Britain to ban professional boxing (amateur boxing can still take place in the borough). After a public debate, Bury councilors voted 23-17 to ban the professional sport. Council leader Derek Bowden said: "Medical evidence showed boxing resulted in unacceptable harm, particularly brain damage, and I believe that we have a duty to care." He added that professional boxing was unacceptable given Bury council's commitment to promoting health and well-being.

The decision infuriated Bury-born British Flyweight Champion Ady Lewis, whose eagerness to defend his title in his home town prompted the council's debate. Lewis' manager Jack Doughty told me: "It's not on. This is not just about Ady, it's about the many other boxers we have down the gym. Ady is very disappointed but we can go elsewhere. These people don't know the first thing about boxing but they are telling us what to do. We are certainly going to fight this decision." The British Boxing Board of Control also plans to contest the ban.

Boxing is billed by its adversaries as a less-civilised form of Russian roulette. But it is safer than they make out. There are medical officers at ringside and referees are encouraged to step in quickly if a fighter is in trouble. Dr Charlie Knowles, a research fellow in surgery at the London Hospital and medical officer of the London Amateur Boxing Association,

In the nineteenth century, the social missionaries set up football clubs in the dark cities of Liverpool, Manchester and Glasgow. In the late twentieth century, the new social missionaries are revamping football in their own image. The mission of the government's task force is to transform stadiums into arenas of social and moral education: thou shalt not stand, thou shalt not offend thy neighbour, thou shalt not insult or abuse the opposition, thou shalt not swear or smoke in the family enclosure. Football today is less of a sport and more like a Sunday school for the nineties, or a morality play for the millennium; and in this respect, it is going back to its roots in the last century.

In their attitudes to football and its supporters, today's politicians rarely display the studs-up stamp-on-them technique associated

reports that 'the incidents of acute injuries requiring any form of hospital attendance are certainly rare, taking boxing as a whole far down the ranks of all sports and below sports such as women's hockey and badminton. It is true that the professional sport has been punctuated by the occasional devastating injury but the number of such instances over the last decade can probably be counted on one hand, and such limited statistics cannot really reflect on the sport as a whole'.

Boxing can be brutal, but it is also exhilarating to watch and to take part in. Fighters gain fitness, confidence and the chance to earn money. The biggest purse yet was \$60 million, shared between Mike Tyson and Evander Holyfield for their rematch earlier this year. With the possible exception of pop music, I cannot think of any other arena in which men from poor backgrounds can earn that kind of money. It makes me think that the current hostility towards boxing bears no relation to the injury-rate among fighters. It is more a reflection of a society in which aggression and ambition are increasingly outlawed, where the sight of young boxers flaunting their trim physique and their fat wallets constitutes an affront to the sensibilities of the new moral missionaries in Bury and beyond.

**Mark Collings** writes for *Amateur Boxing Scene* and trains boxers at St George's ABC in East London

with the Thatcher years. Instead they talk in the language of inclusiveness, fairness and community—the jargon of 'new football'. The language may have changed, but controlling crowds remains a priority. Moreover, football is emerging as a model for the re-ordering of society as a whole. Gary Armstrong said to me over a beer that 'football has always been a convenient receptacle into which to pour political and personal prejudices'. In the new model football, the prejudices of the missionaries against the masses are more virulently expressed than ever before.

*Entering The Field: New Perspectives on World Football*, is published by Berg £34.99 hbk, £14.99 pbk

**Carlton Brick** is a founder member of *Libero!*, the football supporters' network

# It's a little bit more serious .comedy

*Cuddly comic Sean Hughes showed his cynical side to Timandra Harkness*

## Signs of the times

*'Having survived somewhat greater dangers than breakfast, I really think I should be able to make my own decisions on whether the eggs finish me off'*  
 Captain Peter Jones, 88, former bomber pilot. The Albury Park residential home in which he lives with other aged war heroes has stopped serving soft-boiled eggs for breakfast on the advice of environmental health officers.

*The forthcoming autobiography of Air Marshall Sir Peter Horsley, Second World War pilot and former head of Strike Command, will reveal how he spoke with aliens about life on flying saucers, and learned how they carry spare body parts in their luggage.*

# SERIOUS SEAN

If you remember Sean Hughes as the charming but eternally hopeless teenager of Sean's Show, his new novel *The Detainees* may come as a bit of a shock. The main characters lead a bleak existence. 'Why are we so messed up?', John asks himself on page two, prompting me to fear that I was in for 300 pages of existential angst. But besides self-doubt there is a good story here too, and humour, but of the darkest kind.

The challenge Sean set himself was 'can I write a thriller without lots of killings and blackmail?'. It is also a thriller without goodies and baddies. 'I didn't want to have any heroes. That's an easy ride. I want them to see bits of themselves in all the characters.'

David Baddiel and Ben Elton before him have moved from microphone to manuscript, but Sean dismisses any theory that he is part of a gang of comics which is turning to the novel. 'Comics are writers first and foremost', he insists, and this is just a bigger canvas. 'I wanted to get to grips with a fuller story. With stand-up you can really only scratch the surface.'

'The only similarity with the novel and the

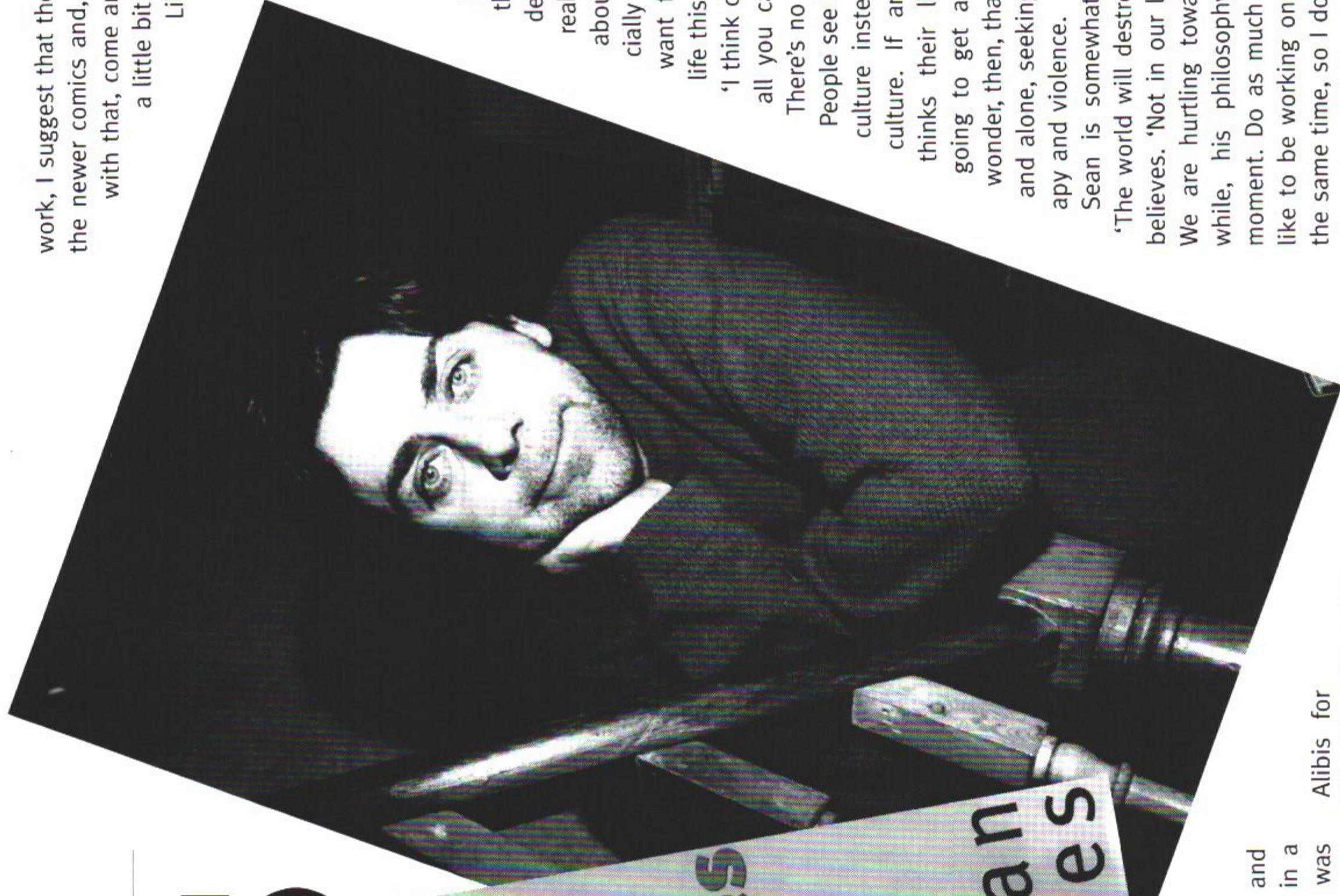

work, I suggest that they go and see some of the newer comics and, when they get fed up with that, come and see something with a little bit more depth.'

Like Sean's new show, *The Detainees* is a book which wants to be deep. Its protagonists are not materially deprived, but there is an air of hopelessness about them, certainly at the beginning. Sean describes them as 'fairly reality-based', and talks about 'telling truths—especially ones that people don't want to hear'. Does he see life this bleakly?

'I think democracy's dead, when all you can vote for is A or B. There's no big thinkers any more. People see happiness in their subculture instead of fighting against culture. If anyone sits down and thinks their life through, they are going to get a bit distraught.' Small wonder, then, that his characters are lost and alone, seeking solace in drugs, therapy and violence.

Sean is somewhat angst-ridden himself. 'The world will destroy itself eventually', he believes. 'Not in our lifetime, but eventually. We are hurtling towards extinction.' Meanwhile, his philosophy is to 'live for the moment. Do as much as you possibly can. I like to be working on two or three things at the same time, so I don't get bored'.

Alibis for Life, the show he took to the Edinburgh Festival, is about a man deciding whether to 'commit' to a woman. 'A lot of that is quite

Sean Hughes tours Britain with *Alibis for Life* in the autumn, before taking the show to Australia. The comedy pop-quiz *Never Mind*



Paul Smith (the fork-lift truck driver, not the designer) has formed English Rights Scotland, to fight anti-English 'discrimination'.

Bristol Rovers have introduced a no-sweating terrace. Meanwhile Sheffield United's new manager,

Nigel Spackman, has decided not to swear at his players. Other clubs are considering following suit, though some are considering designated areas specifically for foul language.

'I was always the one to test out the limitations of the costume. I was the first to fall off my chair and roll over. I took all the risks'

Dave Thompson, the original Tinky Winky of *Teletubbies* fame, who has been told by BBC management that it is time for Tubby bye-byes

BBC weatherman Michael Fish has been reprimanded for sporting a sun tan. This was 'irresponsible', because he was supposed to warn people not to spend too long in the sun.

stand-up would be my first four years of stand-up, when I dealt with childhood a lot. The stand-up's moved on to a different area of my life, so it was really putting a cap on my

admits that 'I was very young when I did *Sean's Show* and I played my vulnerable trump card a bit too much. The new stage show is a lot more cynical, a lot more real.'

dark', says Sean, 'and I make no apologies for that'. Some of his fans are having to be forcibly weaned off the old, easy Sean. 'For anyone who says they want to see my early

# FUNNY GIRLS

**F**awcett's *Funny Girls*: Cartooning for Equality is an exhibition of cartoons about women, men and the battle of the sexes. It is also a showcase for the recently reorganised Fawcett Society, founded more than 130 years ago by the suffragist Millicent Garrett Fawcett.

Curated by Diane Atkinson, who also organised *Purple, White and Green: Suffragettes in London 1906-14* at the London Museum, *Funny Girls* is a treat. Atkinson has drawn together the best gags from both sides in the sex-war, from the campaign for the vote, through wartime working, to current images of career-women and their families.

Ridicule was an important part of the campaign to keep women down, and *Funny Girls* visits a delicious revenge on the anti-suffragettes by showing their work in all its absurdity. The cartoonists of the early twentieth century relied upon 'common sense' prejudice to present an absurd picture of a female parliament (David Low), or a woman speaker in the House of Commons, or simply a household abandoned by a politically active mother (*Punch*). Among the best exhibits is Atkinson's counterposition of John Hassall's drawing of pinched old crones entitled 'Suffragettes who have never been kissed', with the stunningly attractive faces of the real suffragettes.

Wartime cartoons play with the reversal of sexual roles, with women shown in uniform and working in munitions factories, as in the drawing by Giles of a welder being wooed with flowers. As subject matter war work is full of the twists that make for great gags, as well as the erotic charge of sexual ambiguity.

Atkinson sets Posy Simmonds' strip *The World Turned Upside Down*, in which a bullying

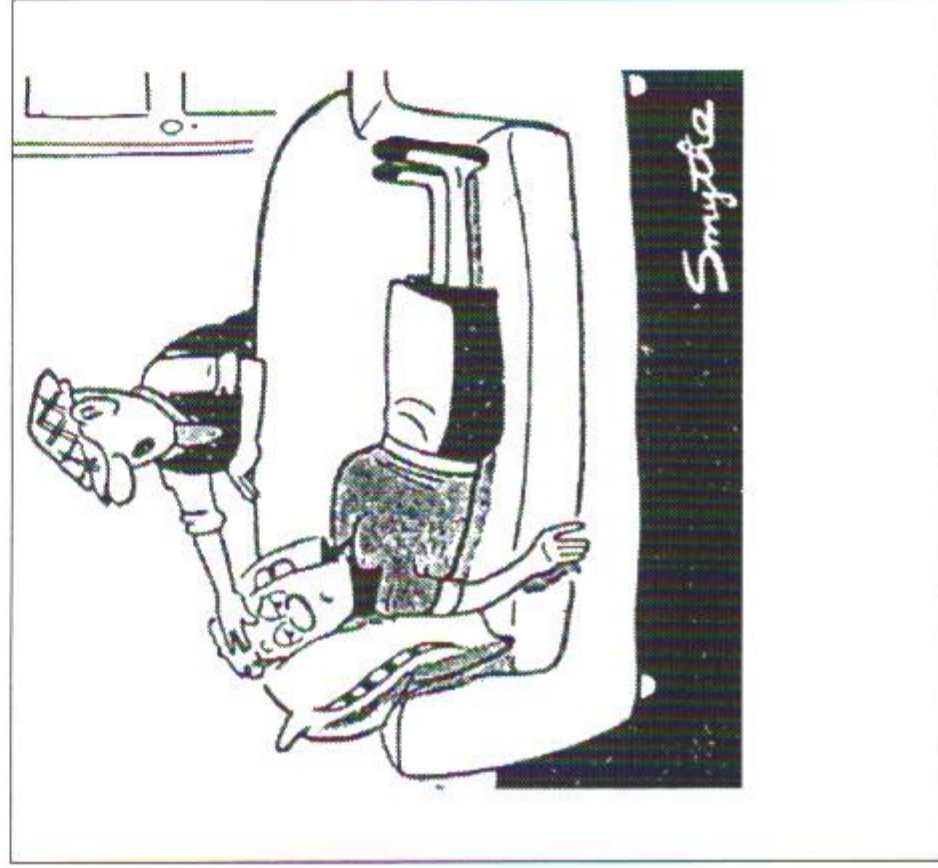

woman boss sends her simpering male secretary out to by some fags, alongside the eighteenth and early nineteenth century engravings which Simmonds was referring to. The originals depict men in harness pulling horses, and, equally ridiculous, a woman going out to work.

One of the merits of *Funny Girls* is that it includes apparently misogynist cartoons like Reg Smythe's *Andy Capp* alongside the work of feminists such as the *Guardian's* Posy Simmonds and Jacky Fleming. Andy Capp has been taking his wife Florrie for granted since 1957. But is this a joke on women or on male chauvinism? Asked if his cartoon reflected his own attitudes, Smythe says cryptically 'it's a toss-up as to who is doing the reflecting—myself or Andy Capp'.

Today's women cartoonists mine a rich vein of hypocrisy among 'new men' who preach equality, but still hang on to the top



## THE PRIMEVAL ARGUMENT

THE PRIMEVAL WOMAN: "Why can't I go out too and see the world?"  
THE PRIMEVAL MAN: "Because you can't. Woman's proper sphere is the Cave."

jobs. Others have turned their attention to the tension between domestic drudgery and career. Fleming's dinner party hostess nonchalantly tosses the washing-up, plate by plate, out of the window. In another cartoon a mother explains to her son that his long-lost father 'is at a workshop for men who missed their daddies when they were little'. So that's what they call a pub nowadays.

**James Hearthfield**

Fawcett's *Funny Girls* is at the Art Connoisseur Gallery, London from 14 October to 27 November. *Funny Girls*, the book of the exhibition, is published by Penguin £9.99 pbk

alt.culture.fiction

## NO GANGSTA

Courtia Newland considers the media coverage of his acclaimed debut novel, *The Scholar*



'I'm a writer. I use my imagination. It's like being an actor. But people try to pigeon-hole you, and a lot of people are making me out to be this gangsta type which I am not. I have said to photographers that I am not

doing another picture on the estate, because I am fed up of them saying "stand by some graffiti", like that's all I am about. It is patronising. For this book here, I suppose I am going to have to take it. The only way I can get round it is by writing more stories and proving I can go elsewhere. Basically they are saying, it's all right for this guy to be writing about urban London or whatever, but that's where it ends. Nearly every interview I have done, this *Boyz 'n the Hood* thing has been brought up.

'Most people just give up trying to change their lives. I see a lot of talented people, who are a lot more interesting than the media people you've got at the moment, and we're told don't think about being a writer, just go and work in a shop. If it wasn't for this book now I would be stacking shelves—that's what I was doing before. People are crushed—not like in *The Scholar*—that doesn't happen to everyone. Most of the time it's a lot more mundane and boring than that. It's just a guy who says "I give up". That is such a waste of people.'

Courtia Newland was talking to **Andrew Calcutt**

*The Scholar* is published by Abacus £9.99 pbk

This appeal was published in the major German weekly, *Die Zeit*, on 11 July 1997, signed by writers, academics and intellectuals as a declaration of support for free speech, and for LM in our battle against ITN's libel writs

# 'FÜR DAS FREIE WORT' IN DEFENCE OF FREE SPEECH

Information is used for political ends, it is used to wield power and influence. Information may help people, it may help them to better grasp the world around them. The very same information may also be used to manipulate and to deceive. It is therefore crucial to draw information from reliable sources and to clarify the context of every piece of information, so the general public may be able to grasp and judge their real meaning.

Images are most prone to manipulation precisely because they create the impression that we can understand a situation by looking at a picture. To enable people to look critically at the world, it is essential for good journalism to ensure that issues and their context are looked at without any prejudice. Today this kind of professional ethos is more and more often brushed aside when dealing with information. In fact, the way journalists deal with information, especially pictures, can often be called unprofessional, if not manipulative.

A particularly scandalous example of this trend was recently revealed by the German *Novo* journalist Thomas Deichmann. During his research on the war in Bosnia, Deichmann came across evidence which proved that a famous picture showing emaciated Muslims behind a barbed wire fence, first broadcast by British news giant ITN in August 1992, was a distortion of reality. This picture, was then generally taken as hard evidence for the existence of Serb-run 'concentration camps'. In reality though, it was not the Muslims who were encircled by a barbed wire fence, but the British journalists who had entered a neighbouring, fenced-in compound to film the Muslims from inside that compound through the barbed wire.

The fact that there were camps in former Yugoslavia run by all factions involved in the fighting and where conditions were frequently bad, makes it all the more important to avoid encouraging a false or one-sided emotional atmosphere.

More than any other footage, this picture has influenced the perception of the war in Bosnia. Quite a few commentators, though,

have not even tried to discuss the importance of Deichmann's revelations on the state of journalism today, but have merely lashed out at them with a flood of denunciations and insinuations, abandoning a rational discussion. And ITN, instead of responding to (or disproving) Deichmann's allegations, launched a libel writ against *LM* magazine, which co-operates with *Novo* and published Deichmann's findings. The only purpose of this libel writ, it would appear, is to prevent the exploration of the truth and to ruin *LM* magazine.

The British libel laws are generally held to be the most repressive in the Western world. They provide rich and powerful institutions and people with a mechanism with which to gag unpleasant critics. Libel writs are notorious for the enormous costs involved and in contrast to other European countries and the USA, in Britain the burden of proof is upon the defendant. The present case is a novelty in media history: for the first time a news corporation is trying to use such repressive laws to suppress news.

We think that in our time of social change, unbiased analysis of facts and the rational sharing of ideas are indispensable. We wish, therefore, to initiate a public debate on how to oppose the trend of information manipulation and narrow-mindedness. We are, furthermore, serious defenders of press freedom and freedom of speech and we will do everything to ensure that the attempted intimidation by ITN will not be successful.

Research, travel expenses, news conferences and PR-work have already cost *Novo* several thousand marks. To go on with its work the magazine needs more donations and supporters. In the law suit between ITN and *LM* magazine we want the better arguments to win—not the side with the more expensive lawyers. To achieve this, we are asking you to sign this appeal and to donate as much as possible. There is more at stake than freedom of information—we have to continually struggle for rational and unprejudiced discussion in scientific, cultural and political debates.

.....  
 PROF DR ULRICH ALBRECHT; PROF DR ASTRID ALBRECHT-HEIDE; ELMAR ALTVATER, UNIVERSITY LECTURER; LOTHAR BAIER, AUTHOR;  
 MIRA BEHAM, WRITER; GEORG BENZ; DAVID BINDER, JOURNALIST (US CORRESPONDENT); KLAUS BITTERMANN, PUBLISHER;  
 .....  
 PROF PIERRE BOURDIEU, SOCIOLOGIST (COLLÈGE DE FRANCE); PETER BROCK, JOURNALIST (EDITOR IN CHIEF *THE REAL WASHINGTON*, USA);  
 THEO CHRISTIANSEN, THEOLOGIAN; EDI CLIJSTERS, JOURNALIST (BELGIUM); DR HEINRICH COMES, LAWYER; CHRISTOPH DAMM, TRADE UNIONIST;  
 .....  
 PROF DR FRANK DEPPE; WOLFGANG EHMKE, TEACHER; RAIMUND FELLINGER, WRITERS' AGENT; DR HANS RUDI FISCHER, THERAPIST;  
 MIRIAM FLEISCHMAN, TRANSLATOR (FRANCE); WOLFGANG FRÄMKE, EDUCATIONALIST; PROF DR PETER GLOTZ; DR NORBERT GREINACHER;  
 .....  
 JENS HAGEN, AUTHOR; PETER HANDKE, AUTHOR; ROLF HARTZUIKER, JOURNALIST (NETHERLANDS);  
 .....  
 DETLEF HENSCHKE, TRADE UNIONIST; LUTZ HERDEN, JOURNALIST (FREITAG); CHRISTINE HORN, JOURNALIST; PROF DR JORG HUFFSCHMID;  
 HUBERTUS JANSSEN, PRIEST; ELFRIEDE JELINEK, AUTHOR; GEORGE KENNEY, WRITER (USA); DIETRICH KITTNER, COMEDIAN; PROF DR REINHARD KÜHNLI;  
 FELICIA LANGER, LAWYER AND WRITER (ALTERNATIVE NOBEL PRIZE WINNER, 1990); MARTIN LETTMAYER, JOURNALIST; HERBERT LEUNINGER, PRIEST;  
 PROF DR BIRGIT MAHNKOPF; MARIANNE MCGEEHAN; JAKOB MONETA, JOURNALIST; WOLF-DIETER NARR; CATARI NETH; DR JAN ÖBERG, (SWEDEN);  
 GUDRUN PAUSEWANG, AUTHOR; ZARKO RADAKOVIC, TRANSLATOR; PROF DR DR HORST-EBERHARD RICHTER, PSYCHOANALYST;  
 .....  
 RENATE RIEMECK, UNIVERSITY LECTURER; PROF DR EBERHARD SCHMIDT;  
 .....  
 MARTIN SINGE, SECRETARY OF KOMITEE FÜR GRUNDRECHTE UND DEMOKRATIE; PETER SINGER, BIO-ETHICIST (AUSTRALIA);  
 SÖREN SOMMELIUS, JOURNALIST (*HELSINGBORG'S DAGBLAD*, SWEDEN); PROF DR MOMMSEN; ECKART SPOO;  
 JOHANO STRASSER, AUTHOR (SECRETARY OF PEN); PROF DR GERHARD STUBY; KLAUS VACK, CIVIL RIGHTS ACTIVIST; PROF DR MARIE VEIT, THEOLOGIAN;  
 WERNER VITT; HANS-JOCHEN VOGEL, PRIEST; ZELJKO VUKOVIC, WRITER  
 .....

# READING

## BETWEEN THE LINES

Reports which claim that poverty and ill health are on the increase are not as worthy as they might seem, suggests TOBY ANDREW

### YOU POOR THINGS

#### DEATH IN BRITAIN: HOW LOCAL MORTALITY RATES HAVE CHANGED 1950s-1990s

Daniel Dorling  
Joseph Rowntree Foundation  
£11.95 pbk

ACCORDING TO THE JOSEPH ROWNTREE Foundation people living in areas with high mortality rates, generally northern cities like Manchester and Glasgow, are now almost twice as likely to die prematurely as those who live where mortality rates are low, generally small towns in the South of England (*Death in Britain*). Richard Wilkinson in his book *Unhealthy Societies* produces figures that seem to show that life expectancy is profoundly affected by social inequality, making relative income the best predictor of health differences. For example infant mortality among unskilled manual workers is twice that of professionals.

The 1995 Rowntree report 'Income and wealth' announced that while average income grew by nearly 36 per cent for the whole population between 1979 and 1992, the gap between top and bottom earners increased so that 'the poorest 20-30 per cent of the population failed to benefit from economic growth'.

These figures certainly make alarming reading, but do they paint the whole picture? Conventional wisdom has it that there is a British underclass, the health of which is suffering because of exclusion from society. A closer examination of the facts of inequality, however, shows that the deprivations of the poorest are largely

#### EQUALITY

Jane Franklin (ed)  
IPPR  
£11.95 pbk

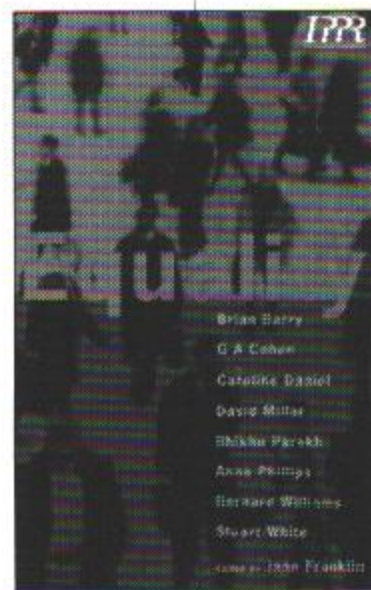

#### UNHEALTHY SOCIETIES: THE AFFLICTIONS OF INEQUALITY

Richard G Wilkinson  
Routledge  
£13.99 pbk

exaggerated, and that the most important division in society—between those who have to work for a living and their employers—has been sidelined from the discussion.

The New Labour government has been torn between a commitment to firm finances and a desire to act upon poverty. On the one hand benefits for single mothers have been cut, but on the other, Downing Street has formed a unit to deal with what it perceives is a growing problem of 'social exclusion'. As an opposition party Labour set up a Social Justice Commission that reported in October 1994, and whose policies are revisited in the report *Equality*, published by the New Labour think-tank the Institute for Public Policy Research. At the centre of social justice, say the authors, is the idea that everybody is entitled, as a 'right of citizenship', to 'be able meet their basic needs'.

Much of the debate on social justice is about the social causes of ill health and whether ill health is caused by poverty. The Joseph Rowntree Foundation study, *Death in Britain*, confirms that although absolute mortality rates for all groups in Britain have fallen steadily since the 1950s, the gap or relative mortality between people living in different areas has widened, particularly since the 1980s. ▶

## WHEN PRINCE PHILIP SAID THAT THERE WAS NO ABSOLUTE POVERTY IN BRITAIN A FEW YEARS AGO, WELFARE ADVOCATES REACTED WITH HORROR—BUT YOU COULD SEE HIS POINT

◀ The report does not, however, try to explain the rise in health inequalities. It might seem obvious that poor people are more likely to become ill and more likely to die at an earlier age than rich people. But what is less apparent and what is contested are the causes of these health inequalities.

Popular accounts of health differences in Britain today often argue that these are because of extremes of poverty. But is it true that poverty has increased over the last 20 years?

The Rowntree report's claim that up to 30 per cent of people became worse off between 1979 and 1992 is clearly an exaggeration, contradicted by other data in the same report. These figures reveal that, while the real net income of the bottom 10 per cent declined or stayed the same over this period (depending respectively on whether the figures cited are 'after housing costs' or 'before housing costs'), the income for the second decile from the bottom stayed about the same and the third decile of the population showed a slight increase in living standards. In reality the report shows that something like 90 per cent of the population over the last 20 years has improved or maintained their living standards.

When the 1995 Rowntree report was published, it sparked a row with rival poverty statisticians signalled by the Institute for Fiscal Studies' publication of a report that showed household spending for the same period increasing for all income groups including the bottom 10 per cent. According to the IFS, if wealth is measured by spending rather than by income, the living standards of all sections of society improved between 1979 and 1992. Indeed in a report 'The changing distribution of the social wage' published in May this year, Rowntree backtracked on its previous report conceding that the income of the poorest fifth of the population grew by 6 per cent between 1979 and 1993, including government spending on education, health and housing the average incomes for this group grew by much as 13 per cent. It is true that the poor benefited less than the better-off, but they did not get worse off in absolute terms.

THE DEBATE BETWEEN WELFARE ADVOCATES like the Joseph Rowntree Foundation and the free marketers like the Institute for Fiscal Studies is fundamentally a debate about whether poverty is to be understood as a relative or an absolute measure. Rowntree's report compares incomes relatively between different income groups. The Institute for Fiscal Studies' proposed changes shift attention from the relative advantages in income to absolute measures like consumption of goods and services.

In a seeming paradox, inequality in Britain soared in the eighties, while at the same time absolute poverty has decreased. This is possible because relative inequality and absolute poverty are two different standards.

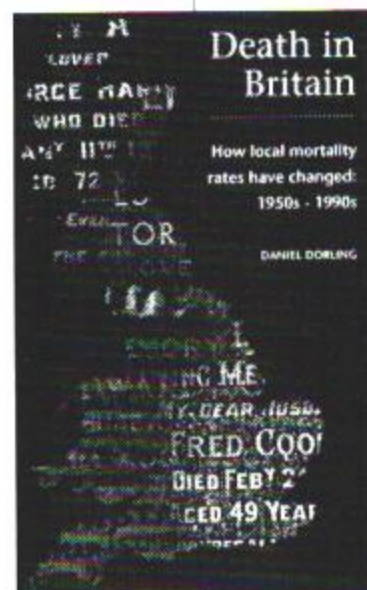

The absolute standard of poverty looks at the material things people consume. The relative standard of inequality looks at the differentials in people's incomes. Absolute poverty can fall while the differentials in income rise.

The official measure of poverty is a relative one, recording all those whose income is less than half the national average, 17.5 million in 1988/9. But on closer examination the figures do not reveal an absolute fall in consumption. This apparently contradictory state of affairs can come about because increased productivity means that more of the things of life are being made more cheaply, but that these are distributed more unevenly. The poorest 10 per cent are getting a smaller slice of a bigger cake.

The argument about absolute and relative poverty has thrown welfare advocates onto the defensive. They think that you need to show people destitute to invoke any public sympathy. When Prince Philip said that there was no absolute poverty in Britain a few years ago, you could see his point. But welfare advocates reacted with horror, fearing that the Prince's comment would encourage public indifference. In response, proponents of more welfare spending have emphasised the impact of inequality upon health, to underline the seriousness of the problem.

The recognition of health inequalities is not new. In 1976 Richard Wilkinson wrote an open letter in *New Society* calling on the Labour government of the day to set up an urgent inquiry into the causes of difference in mortality between social classes in Britain. What subsequently became known as the *Black Report* began a lonely life in the 1980s, suppressed by the government and branded as a left-wing cause, but with its unabridged re-publication in the 1990s all that has changed. Now everybody is talking about poverty and health.

In the introduction to *Unhealthy Societies*, Wilkinson describes 'the long journey' from the study of social class differences in health to the effects of 'income distribution on social cohesion and national mortality rates'. Daniel Dorling, the author of the Rowntree report, says that his study shows disparities in health between regions rather than social classes, but the implications seem clear enough.

The *Black Report* suggests that social causes which contribute to health differences in Britain might include overcrowding, a lack of warmth, and hygiene. However as Wilkinson points out, such factors are unlikely to impact upon overall health figures, simply because the incidence of these hardships are too low. Wilkinson cites DSS figures to show that, of the poorest 20 per cent of the population in 1990/1, 84 per cent had a washing machine, 97 per cent a fridge and 72 per cent central heating, making such explanations unlikely (p46). Although bad housing is associated with increased levels of cancer and heart disease, there is little evidence that

## IN THE MIDST OF ALL OF THE DATA ABOUT HEALTH INEQUALITY, THE HEALTH DIFFERENTIALS UNDER DISCUSSION ARE SURPRISINGLY SMALL AND, SEEN IN THE ROUND, HEALTH IS IMPROVING FOR EVERYBODY

these conditions contribute directly to the causes of death. Damp housing is known to cause an excess of respiratory diseases, but only seven per cent of the total population live in such conditions (p177).

Wilkinson recognises that absolute poverty cannot provide a causal explanation for relative health inequalities. He therefore concludes that relative inequality must be responsible. In the more advanced countries of the OECD, health is not determined by material living standards so much as by relative income or the extent to which income is distributed throughout society, he argues. The evidence for this is the way in which epidemiological data shows that the best predictor for health differences are measures of relative income. This means that measures of income distribution provide a better prediction of mortality than measures of overall wealth, such as the population's median income. Wilkinson argues, health variations within a society are no longer related to the overall wealth of that society, but to the extent to which existing income is distributed throughout society.

A RECENT STUDY FROM THE USA SUPPORTS this idea. The study measured inequality in all 50 states of the USA as the percentage of total household income received by the less well-off 50 per cent of households. What the researchers found was that the greater the inequality in income distribution the greater was the death rate. These results did not change even when they were adjusted for the median income for each state (G Kaplan *et al*, *BMJ*, April 20 1996, pp999-1003). In other words the argument is that it is the gap between rich and poor, and not the actual level of local income, that best predicts the death rate in each state.

Since there are no other intermediaries that provide a stronger prediction of mortality, income inequality is thought to be a literal killer, although the precise mechanism remains unclear. Wilkinson speculates that the underlying causes of excess mortality and morbidity are likely to be 'psychosocial' rather than more 'material' factors such as housing or poor diet. We die younger and are ill more frequently because of the chronic stress involved with living in a hierarchical social order, money worries and so on. There is some evidence, mainly indirect, that chronic stress can contribute to reduced growth, coronary heart disease and even cancer.

Alongside the psychosocial account of health inequality is the argument that bad dietary habits among the poor account for ill health. In April this year the National Food Alliance produced a report arguing that the reason poor people are at greater risk from high blood pressure, heart disease and strokes is because of unhealthy diets, while Save the Children's director-general warned that Britain is facing 'the spectre of child malnutrition' (*Times*, 25 April 97).



In the midst of all of the data about health inequality, it is important to recognise that the health differentials under discussion are surprisingly small and that, seen in the round, health is improving for everybody.

For example the *Black Report* found that, among manual workers in 1984, 13 infants died before the age of one year for every 1000 live births; for professionals the figure was 6.5 in every thousand—half as many. In 1930-32 the corresponding figures were 80 and 32 out of 1000, in 1949-53 the figures were 42 and 19 out of 1000, and in 1970-72 the figures were 31 and 12 out of 1000 births (quoted in 'A phantom carnage', Social Affairs Unit, 1993). In other words, while relative infant mortality has remained pretty constant for much of this century (by a factor of about two), the absolute figures for infant mortality have declined for all classes.

Although it is true that health is only weakly related to economic growth at any given point in time, there is a strong relationship between the two over time. In fact life expectancy has on average increased by 2-3 years every decade this century. Perversely Wilkinson argues that it is both possible and desirable to have improvements in quality and scientific innovation without economic growth. Health indices, Wilkinson argues, should be used to form better measures of living standards than economic indicators, because these indices take into account quality of life and not just standard of living as conventional economic measures do.

Wilkinson's approach is artificially to separate the economy from the issue of how people's needs are to be met. In the 'epidemiological transition' he describes, basic needs such as health and a minimum income are taken for granted since both no longer appear to be contingent upon economic growth. The economy is something that cannot be altered, but exists autonomously. As a result he calls for the 'demotion of economic growth from its role as a societal goal' (p222).

Wilkinson's attempt to separate the issue of how needs are met from the broader issue of economic growth shows the extent to which the issue of inequality has been depoliticised. No longer is the division of society's resources subject to the annual row of the wage round. Today's debate is the property of a small clique of professionals in the health and welfare sectors and fixates upon the most narrowly technical definitions of poverty and 'basic needs'. The attempt to redefine social inequality in medical terms, as if it were simply a flu epidemic, is the culmination of its depoliticisation.

As Wilkinson's own research shows, even seen in medical terms, the effects of poverty are not reducible to human biology. Rather, the most onerous aspect of low incomes is the differential social position that these embody—the very relative disadvantage that seems so unworthy of our interest. However, the characterisation of relative inequality in psychosocial terms is no step forward. ►

◀ Turning our attention to questions of esteem and social exclusion, as New Labour would like, might seem to be a more all-rounded approach. But in fact it only further separates the issue of inequality from that of social production, emphasising the individual psychology of the 'excluded'. In this discussion a job is not seen as a way that an individual earns a living or makes a real contribution to society's wealth. Rather it is seen as a way that a person gets 'self-esteem' and feels as if he is making a contribution to society. This is an assessment that turns even a real job into a consumption good, or even a counselling session, as if working were just another status symbol. In policy terms this is the agenda of the Restart programmes, in which jobseeker advisers probe 'clients' as to the motivational barriers they have to finding work, and all work is reduced to the level of work-experience.

At the heart of the discussion of inequality is a belief that the question of production itself is closed. The fact that all of society's needs are met through work does not feature in the current discussion of inequality, no more than that most people meet their basic and not-so-basic needs by working for a living. Instead, the goal is to curb the worst excesses of unequal income distribution. Of course that means that the central source of social inequality within the realm of production itself is obscured: the few who own the country's firms and industries are able to keep the lion's share of the social product for themselves; the many who have to work for a living are only very rarely allowed to earn enough to make themselves independent.

IN THE DEBATE BETWEEN GOVERNMENT AND welfare advocates all attention is on the very poorest 10 per cent. The vast majority of working people do not feature in this discussion, only those at the extremes: the greedy rich 'fat cats' and the feckless poor of the 'underclass'. But the most spectacular income inequalities are between the top 10 per cent and the rest. The fact that the class of wage workers have managed to defend their incomes, often by taking on extra work, means that the welfare advocates are not concerned for them (if anything, it is the 'work rich' who are blamed for making the poor poor). The poverty professionals are only interested in people that they can patronise.

The attempt to redefine poverty as a medical and health issue is a further step down that road. Concentrating upon the psychosocial problems of poverty can only lead to a greater regulation of the poor, through closer integration of health professionals, social services and the Employment Service. The ominous signs of dietary regulation are already evident, as are the curbs on such simple pleasures as tobacco and alcohol, all imposed 'for their own good' of course.

READ ON READ ON **READ ON** READ ON READ ON READ ON READ ON

### WALL STREET: HOW IT WORKS AND FOR WHOM

Doug Henwood, Verso, £20 hbk

Wall Street is that most rare thing, a critique of capitalism that knows what it is talking about. Doug Henwood has been writing about Wall Street for some time. He produces the *Left Business Observer*, subtitled 'accumulation and its discontents', which looks like a cross between a bulletin for investors and a revolutionary manifesto. Henwood's insider knowledge of Wall Street means that he can be as radical as he likes, without being shrugged off as inconsequential.

Henwood is scathing about the idea that the stock market and its financial off-shoots exist to mobilise resources for production. As he points out, that is not what they have been doing. If anything the mergers and shake-outs are about taking resources out of production where profits are low. Over and over again Henwood emphasises the divergence between making money on the markets and real production. As he points out, growth in the stock exchange can as easily reflect faltering production as a boom.

Henwood reports the growth of investor-power in the USA, the increasing clamour for a greater return on their stock. Astutely, he traces its origins to the first stirrings of ethical investment, when small investors first started to make their voices heard at shareholders meetings by demanding disinvestment from apartheid South Africa. But as Henwood notes, what started with the highest of intentions quickly turned into furious demands for bigger dividends, to be paid for by more lay-offs.

Henwood's sources are eclectic: the most up-to-date neo-Keynesians jostle Sandor Ferenczi's psychoanalytic theories of money, Karl Marx's *Capital* and even the lyrics of a song by seventies punk band the *Slits*. But what keeps Henwood sharp is his basic intuition that it is the whole system that is at fault, not any singular feature of it. Introducing a chapter on the key players, he says that he could go on about Ivan Boesky and other disgraced traders, but that would only make the rest look artificially good. And, by way of a conclusion ('What is (not) to be done'), Henwood explains the weakness of every piecemeal scheme of reforming the markets, from ethical capitalism, to democratising the federal bank.

In that spirit he knows, too, that the current trend for knocking the financial markets only to praise capitalist industry must be wrong. The reason is that the perverse growth of the financial markets is a symptom of the slowdown of capitalist investment, but not its cause.

James Heartfield

# THE POINT IS TO CHANGE IT

'Our reply to all of the pleas for caution and restraint is that until now humanity has only learned to crawl. We still live in a world that is not fit for people. Our problem is not that we are too ambitious, but that we continually hesitate about experimenting with new solutions. We need a revolution in outlook, so that we can continue to advance and give new scope to human creativity.'

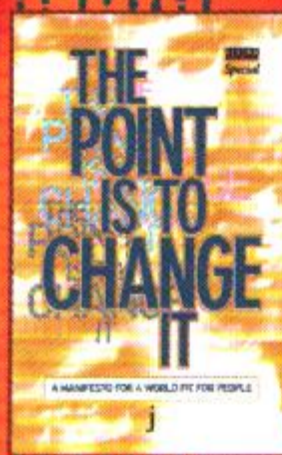

Available from all good bookshops,  
price £9.95. Or write to  
JP Graphics Ltd, BM JP Graphics,  
London WC1N 3XX.  
Add £1 for postage and packing. Make  
cheques payable to 'JP Graphics'

**A MANIFESTO  
FOR A WORLD FIT FOR PEOPLE**

published by

**jp GRAPHICS LTD**

ISBN 0 948392 22 3

**LM** libel appeal

The **OFF THE FENCE** fund

**ITN**

tried to have every copy of February's *LM* magazine

**PULPED,**

to stop people reading our story about their award-winning pictures of a Bosnian camp.

The magazine refused to comply with that gagging order.

Now ITN is trying to silence *LM* by suing for

**LIBEL,**

a censorship law that the rich can hire to stitch up their critics.

We need your help to defend press

**FREEDOM**

against this unprecedented attack by a media giant.

Send donations to: **BM OFF THE FENCE  
LONDON  
WC1N 3XX**

Make cheques payable to: **OFF THE FENCE FUND**

